

Megaplex-4

VS

Multiservice Module



- Broad variety of services
- E1/T1, FXS, FXO or E&M toll-quality analog voice channels, input/output binary command ports, OCU-DP – DDS, IEEE C37.94 dual optical link
- 6/12 serial sync/async data interfaces, configurable (per port) serial interface types and data rates of 2.4 kbps to 1984 kbps
- Bidirectional broadcast for easy interconnection of multiple control centers to remote RTUs/IEDs
- Pseudowire or Ethernet over PDH support

VS multiservice modules provide a variety of interfaces, including serial, binary command, OCU-DP – DDS, C37.94, voice, and E1/T1. The modules employ an embedded pseudowire engine used for low-latency transmission of TDM services over packet-switched networks.

ARCHITECTURE

VS-12 modules consist of two identical submodules each featuring a serial interface with 6 sync/async channels.

VS-6/BIN consists of the following submodules:

- Upper: serial interface submodule with 6 sync/async channels
- Lower: binary command submodule with 8 inbound (cmd-in) and 8 outbound (cmd-out) ports.

VS-6/703 consists of the following submodules:

- Upper: serial interface submodule with 6 sync/async channels
- Lower: G.703 submodule with 8 G.703 codirectional 64-kbps ports.

VS-6/C37 consists of the following submodules:

- Upper: serial interface submodule with 6 sync/async channels
- Lower: C37.94 submodule with 2 IEEE C37.94 fiber optic ports.

VS-6/FXS, VS-6/FXO, VS-6/E&M modules consist of the following submodules:

- Upper: serial interface submodule with 6 sync/async channels
- Lower: voice submodule with 8 FXS, 8 FXO or 4 E&M ports.

FXS/E&M module consists of the following submodules:

- Upper: voice submodule with 8 FXS ports.
- Lower: voice submodule with 4 E&M ports.

VS-OCU-DP/E&M module consists of the following submodules:

- Upper: OCU-DP – DDS submodule with 2 OCU-DP – DDS ports
- Lower: voice submodule with 4 E&M ports.

VS-6/E1T1 consists of the following submodules:

- Upper: serial interface submodule with 6 sync/async channels and 8 E1 or T1 ports
- Lower: E1/T1 submodule with 8 soft-selectable E1/T1 ports.

VS-16E1T1 consists of two identical E1/T1 submodules each featuring 8 soft-selectable E1/T1 ports.

SERIAL INTERFACE

The serial data rates in the VS modules are independently selectable for each channel and depend on the selected encapsulation mode.

The interface terminates in 68-pin SCSI-4 female connectors. Each submodule contains 2 connectors; each connector includes 3 channels. The module provides a simple and easy SW-configurable selection of serial interface (V.35, RS-422 or RS-232) according to the deployment needs.

Adapter cables, available upon order, are offered by RAD to split each module connector into three separate channel interfaces with standard connectors: V.35, RS-530, RS-232, X.21 or V.36/RS-449.



VS

Multiservice Module

Encapsulation Modes

VS modules behave like different types of modules on selection of the specific encapsulation mode:

- **None:** each channel operates at high-speed rates of $n \times 56$ or $n \times 64$ kbps, where $n = 1$ to 31 (that is, maximum 1984 kbps).
- **V110:** each channel operates at low-speed rates of 2.4, 4.8, 9.6, 19.2 or 38.4 kbps, performing rate adaptation in accordance with ITU-T Rec. V.110.
- **3-bit transitional:** the module provides transitional encoding to transmit asynchronous data at rates up to 19.2/38.4 kbps. It operates by encoding asynchronous data in a 3-bit transitional code, which is then transmitted over the Megaplex uplink at a rate of 64/128 kbps.
- **R111:** the module provides transitional encoding to transmit asynchronous data at the rates of up to 19.2 kbps. It operates by encoding data in a 3-bit transitional code, which is then transmitted over the Megaplex uplink at a rate of 64 kbps.

- **HCM (High-Capacity Multiplexing):** the module transmits synchronous/asynchronous data over 64 kbps based on multiplexing with a DS0 timeslot. This Newbridge proprietary rate-adaption and sub-rate multiplexing scheme provides a bandwidth granularity of 800 bps throughout a network, by formatting low speed data into 10 bytes frame.

Interface Control Signals

Each channel has local support for interface control signals (CTS, RTS, DCD, DSR and DTR). Alternately, each channel can be configured to transmit control signals end-to-end.

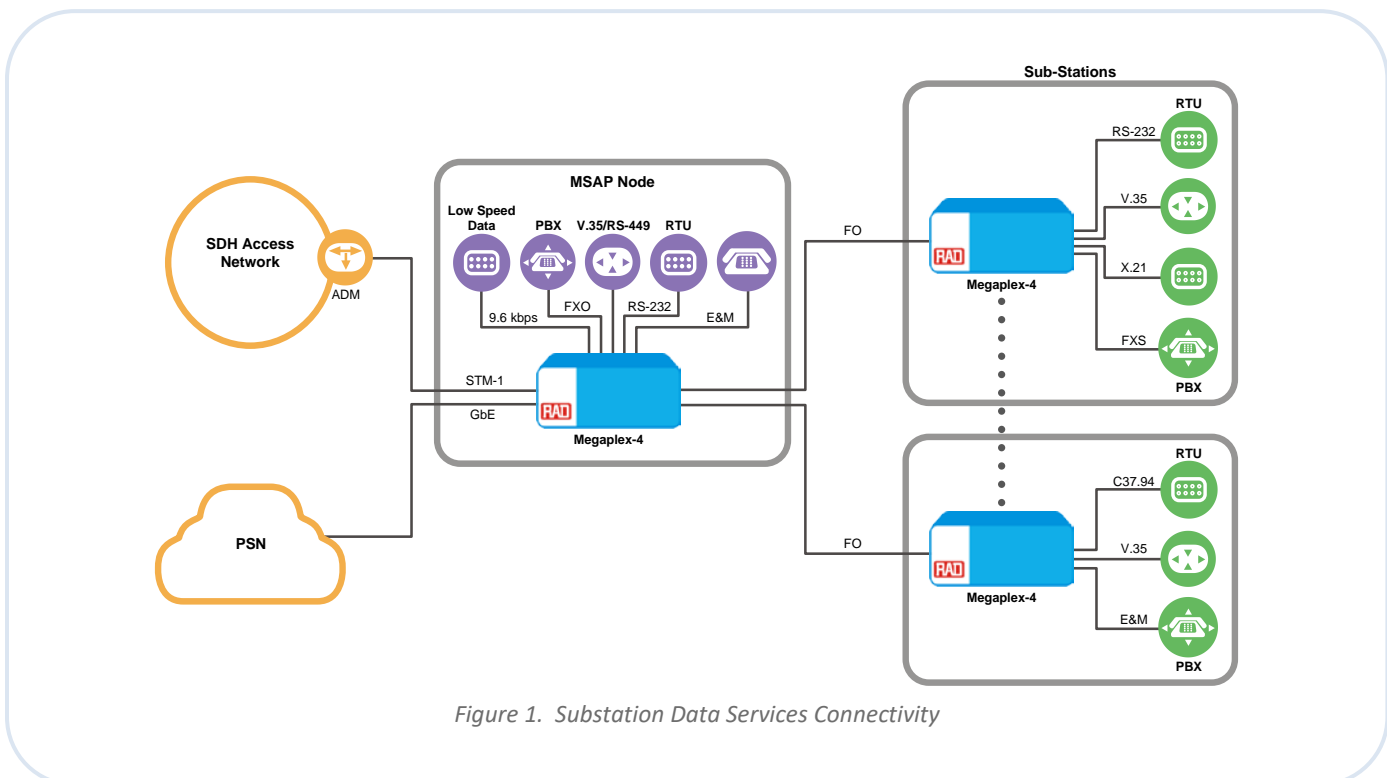

Figure 1. Substation Data Services Connectivity

VS

Multiservice Module

E1/T1 INTERFACE

E1/T1 modules feature various combinations of E1/T1 and serial ports per module with optional PW or Ethernet over PDH support.

PW options can act as servers for other I/O modules, providing up to 16 protected PW connections. E1/T1 traffic is transported over CES/SAToP, including adapting timing support (ACR).

A special option provides ETHoPDH connectivity over E1/T1 links.

E1/T1 options are SW-selectable.

BINARY COMMAND INTERFACE

The VS-6/BIN module provides the following functions:

- 8 binary input ports (cmd-in) – enable the management system to read inbound indications from external sources.
- 8 binary output ports (cmd-out) – provide outbound indications and control signals by means of dry relay contacts.
- Two cmd-channels (1, 2) are used to transport binary information over the telecommunications network via end-to-end reporting: the input command is transferred to the remote location via a selected timeslot and affects the corresponding output.

The user can monitor the state of each inbound or outbound port by means of indicators located on the VS-6/BIN front panel or from the management system status display.

The binary commands can be locally output or be carried to a peer card/Megaplex over a TDM network or over a packet switched network. Up to 4 in/out commands can be carried over a single DS0.

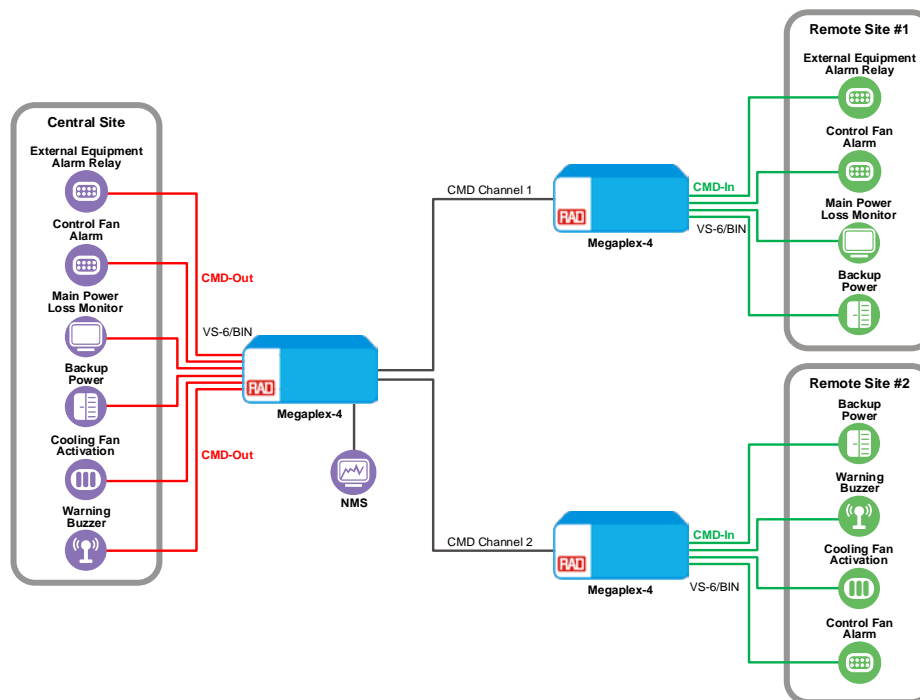

Figure 2. Input/Output Binary Relay Commands in a Point-to-Multipoint Deployment of a VS-6/BIN Module

VS

Multiservice Module

Binary Inbound (CMD-IN) Ports

The VS-6/BIN module has 8 inbound ports, which enable it to report alarms external to the Megaplex-4 unit, and report physical conditions in remote locations to a central management station.

The VS-6/BIN module can be configured by the user to interpret the state of each input and report events to the CL module of the local Megaplex-4. For each event, the CL module sends the corresponding alarm message/SNMP trap to the supervision terminal and network management stations. Each event can be associated with a user-selected message that describes the situation or prompts the remote user to take a prescribed action.

Binary Outbound (CMD-OUT) Ports

The VS-6/BIN module has 8 outbound ports equipped with change-over dry relay contacts. The default state (the state of the relay contacts when Megaplex-4 is operating) can be selected by the user, individually for each outbound port.

The relay contacts report internal system alarms to outside indicators and control external devices or applications. Each relay can be controlled by a specific event in the network, in accordance with configuration.

G.703 INTERFACE

The VS-6/703 module provides Megaplex-4 with 8 64-kbps G.703 codirectional data channels (ports). Each channel can be independently enabled or disabled by software configuration.

C37.94 INTERFACE

The VS modules feature a dual-port fiber optic interface, operating at a nominal wavelength of 830 nm and nominal line rate of 2.048 Mbps. Each port is terminated in a pair of ST connectors for connection to standard multimode fiber.

The interface complies with IEEE C37.94 standard for distances of up to 2 km.

The interface can be used for both user and network ports – either for inter-substation communication or for transmitting distance Teleprotection information.

OCU-DP – DDS INTERFACE

The OCU-DP – DDS interface provides direct connection to products with a built-in CSU/DSU. It is also used with standalone CSU/DSU products for connection to DDS networks.

Each OCU-DP – DDS channel is compatible with AT&T PUB 62310 (Standard DDS) and BELLCORE TA-TSY-0000777, and operates at data rates of 56 and 64 kbps.

VOICE INTERFACE

The VS voice submodules provide 8 FXS, 8 FXO or 4 E&M toll-quality analog voice channels. Voice signals are digitized using PCM, in compliance with ITU-T G.711 and AT&T Pub. 43801 standards.

Encoding and decoding are in full compliance with ITU-T requirements G.711. Voice channel companding is selectable for A-law or μ -law.

The modules are available with E&M, FXO and FXS interface types.

VS-6/FXS, VS-6/FXO, VS-6/E&M and VS-8/E&M modules are available in additional, advanced versions featuring enhanced PW capabilities – in particular, adaptive clock recovery (ACR).

The **E&M** interface operates with different types of E&M signaling: EIA RS-464 Types I, II, III and V (British Telecom SSDC5). Both 2-wire and 4-wire lines are supported (user-selectable).

The E&M modules provide EIA RS-464 Type I signaling without the need for an external DC power supply. For other signaling types, the internal -12 VDC provided by the chassis is sufficient for connection to most PBX systems.

However, for *full* support of EIA RS-464 Types II, III and V (BT SSDC5) standards, a -48 VDC power source is required. This voltage can be supplied via Megaplex PS AC or DC modules.

The FXS interface employs both loop-start and wink-start signaling methods. FXS interfaces are typically used for direct connection to 2-wire telephones.

When operating in PCM mode, battery polarity is reversed for wink-start signaling, used in direct inward dialing (DID) applications.

The FXO interface employs both loop-start and wink-start signaling methods. It can be used for connection to PBX extension lines in point-to-point, loop-start applications, with a corresponding FXS VS or VC module at the remote Megaplex connecting to the remote extension. The battery polarity is reversed for wink-start signaling.

Gain control is user-selectable for both the receive and transmit directions, enabling easy installation in all environments.

PSEUDOWIRE

A powerful pseudowire engine can act as a server card to other I/O modules. Depending on the card type, the engine provides up to 12 or 16 protected PWs per module with up to 32 timeslots per each PW port.

The module features direct mapping of the local interfaces to PW port with reduced latency and built-in jitter buffer with configurable depth.

A series of PW-enhanced VS modules have independent adaptive clock recovery (ACR) mechanisms for each pseudowire, which recover the original timing (clock rate) of the far-end source of each pseudowire, according to ITU G.8261, G.823, G.824 and MEF 22 recommendations. The clock recovery mechanisms can provide recovered clock signals to serve as timing references for Megaplex-4.

VS modules perform fault propagation.

ETHERNET OVER PDH

VS modules transport Ethernet traffic over PDH infrastructure via the following technologies:

- Generic Framing Procedure (GFP G.8040)
- Virtual Concatenation (VCAT G.7043)
- Link Capacity Adjustment Scheme (VCAT G.7042).

CROSS-CONNECT

The bidirectional broadcast mode enables a user at a central location to communicate with several users connected to remote Megaplex-4 units, using polled communications.

It is used mainly for SCADA applications in which a SCADA controller is polling multiple RTUs/IEDs at a central site (see *Figure 3*).

Each remote device is listening to the traffic sent by the central controller and responds when it is being polled.

At the central site all the traffic from the remote site is aggregated by the VS card.

MANAGEMENT

All module operating parameters are soft-selectable through the Megaplex management.

Specifications

SERIAL INTERFACE

Async Character Format	Length: 5,6,7,8 Parity bit: yes, no Stop bits: 1,2
Clock Mode	DCE (VS channel provides both RX and TX clocks to the user DTE)
Connectors	Four/two 68-pin SCSI, female (one per 3 data channels)
Diagnostics (per port)	Local digital loopback Remote digital loopback
Data Channels per Module	VS-12: 12 Other VS modules: 6
Encapsulation Modes and Data Rates	None: n×56 or n×64 kbps (n = 1 to 31) V.110: 2.4, 4.8, 9.6, 19.2, 38.4 kbps R.111: 2.4, 4.8, 9.6, 19.2 kbps 3-bit-transitional: 64 kbps, 128 kbps HCM: 2.4, 4.8, 9.6, 19.2, 38.4 kbps
Interface (Electrical)	V.24/RS-232, V.35 or V.11/RS-422 RS-485 (4-wire only)
Interface (Physical)	V.24/RS-232, V.35, V.36/RS-449, RS-530, X.21 (via adaptor cables)
Interface Control Signals	Local support for all types of control signals End-to-end transfer of local RTS and DTR lines
Signal Format	Asynchronous or synchronous, full duplex

BINARY INTERFACE

Compliance	IEEE 1613 (USA standard for equipment in electrical switching stations)
Connector	DB-44
Inbound Ports	Number: 8 Maximum Input Control voltage: ±60 VDC Command trip point: <ul style="list-style-type: none"> • Above – 24 VDC ON • Below – 18 VDC OFF
Isolation	All input and outputs are galvanically isolated
LED Indicators	Name: CMD IN/OUT Number: 8 Color: Green/Yellow Green blinking: cmd-in port is active Red blinking: cmd-out port is active Green/Red blinking: cmd-in and cmd-out ports are both active Off – port is not active or not connected

Outbound Ports	Number: 8
	Relay type:
	<ul style="list-style-type: none"> Electro-mechanical relay (EMR) Solid-state relay (SSR)
	Closed Contact Parameters:
	<ul style="list-style-type: none"> Impedance: < 0.1 Ohm Maximum current: <ul style="list-style-type: none"> EMR: <ul style="list-style-type: none"> AC: 8A, 250 VAC DC: 8A, 30 VDC – 0.3A, 300 VDC SSR: 0.12A Minimum current (SSR only): 0.1 mA
	Maximum DC voltage across open contacts: 60 VDC

G.703 INTERFACE

Compliance	ITU-T Rec. G.703, Section 1.1.4.1
Connectors	RJ-45 (one for each channel)
LED Indicators	ALM (red): <ul style="list-style-type: none"> Lights steadily – the corresponding port detects LOS Flashes – the corresponding port detects OOS pattern Off – the corresponding port is not connected.
Nominal Data Rate	64 kbps
Number of Ports	8

C37.94 INTERFACE

Compliance	IEEE C37.94, optical part
Connectors	Pair of ST connectors, female
Diagnostics (per port)	Local digital loopback Remote digital loopback
Fiber Type	62.5/125 μ m multimode 9/125 μ m single mode 50/125 μ m multimode

LED Indicators	SYNC (green/red): <ul style="list-style-type: none"> Lights steadily in green – the corresponding port is operating properly Flashes in green – the corresponding port is operating properly, but serves as the standby port when link protection is enabled Lights in red – the corresponding port detects loss of synchronization or loss of signal Flashes in red – the corresponding port serves as the standby port, and detects loss of synchronization REM SYNC (yellow): <ul style="list-style-type: none"> On – the corresponding port detects loss of remote synchronization Off – the corresponding port is not connected.
-----------------------	---

Minimum Receiver Sensitivity	Multimode: -32 dBm Single mode: -35 dBm
Maximum Receiver Input Power	Multimode: -11 dBm Single mode: -5 dBm
Nominal Data Rate	2.048 Mbps
Number of Ports	2
Power Coupled into Fiber	62.5/125 μ m: -11 to -19 dBm 9/125 μ m single mode: -5 to -10 dBm 50/125 μ m: -11 to -23 dBm
Range (Typical)	Multimode: 2 km/1.25 miles Single mode: 40 km/25 miles
Receiver Dynamic Range	Multimode: 21 dB Single mode: 30dB
Transmitter Type	Multimode: LED Single mode: Laser
Wavelength	Multimode: 850nm \pm 40nm Single mode: 1310nm \pm 50nm

E1/T1 INTERFACE

Connectors (per submodule)	DB-44, female for each 8 ports (see Ordering for cables available from RAD)
Diagnostics (per port and per timeslot)	Local digital loopback Remote digital loopback BER Test on E1 ports of selected VS modules
Ports	8 E1/T1 ports per submodule E1 or T1 option soft-selectable, same for all module ports

E1 INTERFACE

Compliance	ITU-T G.703, G.704, G.732 (Including CRC-4 and E bit)
Framing	2 frames (G732N), or 16 frames (G732S) per multiframe, with or without CRC-4 Unframed
Data Rate (per port)	2.048 Mbps
Line Code	HDB3
Signal Level	Receive: 0 to -12 dBm Transmit: Balanced: $\pm 3V$ ($\pm 10\%$) Unbalanced: $\pm 2.37V$ ($\pm 10\%$)
Jitter Performance	As per ITU-T G.823
Impedance	Balanced 4-wire: 120Ω Unbalanced coax: 75Ω

T1 INTERFACE

Compliance	ANSI T1.107 and T1.403
Data Rate (per port)	1.544 Mbps
Framing	ESF
Impedance	Balanced 4-wire: 100Ω
Jitter Performance	As per AT&T TR-62411
Line Code	Bipolar AMI
Zero Suppression	Transparent, B7, B8ZS
Signal Level	Receive: 0 to -12 dBm Transmit: 0.6, 1.2, 1.8, 2.4, 3.0 dBm user-adjustable, measured at 0 to 655 ft

OCU-DP – DDS INTERFACE

Number of Data Channels	2
Interface	Compatible with AT&T PUB 62310 (Standard DDS), BELLCORE TA-TSY-000077
Connectors	RJ-45 per channel
Diagnostics (per channel)	Local loopback Remote loopback (OCU loopback) Remote loopback on external unit (CSU loopback)
Alarms (per channel)	Loss of signal Out of service (OOS), 56 kbps only Idle state (end-to-end support), 56 kbps only
Data Rates	56 or 64 kbps, full-duplex

Line Rates	56 kbps: 56 kbps 64 kbps: 72 kbps
Mapping to Megaplex Timeslots	56 kbps: single DSO 64 kbps: two DSO
Line Code	AMI
Timing	Locked to the Megaplex nodal timing
LED Indicators (per channel)	LOS (red): Lights steadily when a loss of signal condition is detected by the channel TEST (yellow): Lights steadily when a local or remote loopback is activated

VOICE INTERFACE – GENERAL

Bandwidth Requirement	64 kbps (one timeslot) per enabled channel
Connectors	E&M interface: 4xRJ-45 FXS/FXO interface: 4xRJ-12 (one per two channels)
Diagnostics	Local digital loopback for each channel, towards the local user equipment Remote digital loopback for each channel, towards the remote user equipment 1 kHz, 0 dBm0 test tone injection for each channel, towards the remote user equipment 1 kHz, 0 dBm0 backward test tone injection for each channel, towards the local user equipment
Far-end Cross-talk (2W&4W)	-65dBm0 max
Frequency Response (Ref:1020 Hz)	± 0.5 dB at 300 to 3000 Hz ± 1.1 dB at 250 to 3400 Hz
Go-to-return Cross-talk (4W)	-60dBm0 max
Idle channel noise	better than -65 dBm0 (+25 dBnc)
Level Adjustment	Soft-selectable, see Table 1
Line Type	E&M: 4-wire or 2-wire (soft-selectable) FXS, FXO: 2-wire ITU-T standard: G.712
Nominal Level	0 dBm
Nominal Impedance	600Ω
Number of Voice Channels	FXS/FXO: 8 ports per submodule E&M: 4 ports per submodule
Return Loss (ERL)	at 300 to 3400 Hz: better than 20 dB
Steps	0.5 dB (± 0.5 dB), nominal
Signal to Total Distortion (G.712)	-30 to 0 dBm0: better than 33 dB -45 to +3 dBm0: better than 22 dB
Voice Encoding Technique	Per ITU-T G.711 and AT&T Pub. 43801, μ -law or A-law

E&M INTERFACE

Indicators	M – On when the M line of the corresponding channel is off-hook (channel in use)
	E – On when the E line of the corresponding channel is off-hook (channel in use)
Pulse Dial Distortion	±2 msec max
Signaling Method (selectable)	EIA RS-464 Type I EIA RS-464 Types II, III, and V (British Telecom SSDC5) using -12 VDC in place of -48 VDC Note: For full support of Types II, III, and V (SSDC5) signaling standards, -48 VDC power supply is required.
Transformer Isolation	1500 VRMS

FXS INTERFACE

Feed Current	20 mA (±10%) per active channel
Indicators	Number: 8 Color: green/yellow Name: LOC/REM Lights steadily in green – Local “OFF-HOOK” Lights steadily in yellow – Remote “OFF-HOOK” Flashes in green/yellow – Local and Remote “OFF-HOOK”/conversation state Off: port is not connected or both directions of signaling are “ON-HOOK”
Loop Resistance	Min: 300Ω Max: 1600Ω
Number of Channels	Ringer-2100R: up to 40 Ringer-2000: up to 100 Ringer-2200N: up to 200
On-Hook/Off-Hook Threshold	Off-Hook: Loop current >11 mA On-Hook: Loop current <8 mA
Ringer	Overload protected, 1 sec ON, 3 sec OFF 54 VRMS with up to 1 REN load 45 VRMS with up to 5 REN load
Reverse Polarity Pulse Distortion	6 msec max
-48 VDC (nominal) Current Consumption	30 mA (±10%) per active channel
Signaling Methods	EIA RS-464 loop-start or wink-start

FXO INTERFACE

DC Impedance	Off-Hook: 160Ω at 50 mA feed 270Ω at 25 mA feed On-Hook: 20 MΩ
Indicators	Number: 8 Color: green/yellow Name: RING/REM Lights steadily in yellow – Remote “OFF-HOOK” Lights steadily in green – Ringing is received on the corresponding channel Off: Port is not connected or Remote “ON-HOOK” state with ringing not received on the corresponding channel
Reverse Polarity Pulse Distortion	6 msec max
Ring Detector	Ring Impedance: 20 MΩ Detection: >16.5 VRMS, 13–68 Hz No detection: <13.5 VRMS
Signaling Methods	EIA RS-464 loop-start or wink-start

PSEUDOWIRE

Standard Compliance	IETF: RFC 4553 (SAToP), RFC 5086 (CESoPSN) MFA Forum: IA 8.0.0 MEF 8 Note. Non-E1/T1 VS modules do not support SAToP.
Number of PW Connections	32 per module (up to 640 per chassis)
Jitter Buffer Size	All /PW modules: 0.25–256 msec, in 1 μ sec steps with 125 μ sec granularity (the value entered by the user is rounded upward to the closest $n \times 125 \mu$ sec value) Other VS modules: 0.25–8 msec, in 1 μ sec steps with 125 μ sec granularity (the value entered by the user is rounded upward to the closest $n \times 125 \mu$ sec value)

DIAGNOSTICS

Local and remote digital loopback per DS1 port timeslot	all VS modules
Local and remote digital loopback per entire DS1 port	VS-6/E1T1, VS-16E1T1/PW, VS-6/703, VS-6/FXS/PW, VS-6/FXO/PW, VS-6/E&M/PW

GENERAL**Power Consumption (max.)**

VS-12	RS-422: 16.7W RS-232: 13.5W V.35: 15.9W
VS-6/BIN	RS-422: 14.7W RS-232: 13.0W V.35: 14.2W
VS-6/C37	RS-422: 12.9W RS-232: 11.3W V.35: 12.5W
VS-6/4E&M	RS-422: 17.0W RS-232: 15.4W V.35: 16.6W
VS-8/E&M	17.4W
VS-6/8FXO	RS-422: 13.9W RS-232: 12.3W V.35: 13.5W
VS-6/8FXS	RS-422: 14.7W RS-232: 13.1W V.35: 14.3W
VS-6/703	RS-422: 16.0W RS-232: 14.4W V.35: 15.6W
VS-8FXS/4E&M	15.1W
VS-OCU-DP/4E&M	11.5W
VS-16E1T1-EoP	14.5W
VS-16E1T1-PW	14.5W
VS/8E1T1/PW	RS-422: 16.1W RS-232: 14.5W V.35: 15.7W

Configuration

Programmable via the Megaplex management system

Environment

Operating Temperature	-10°C to +55°C (14°F to 131°F)
Storage temperature	-20°C to +70°C (-4°F to +160°F)
Humidity	up to 95%, non-condensing

Ordering

MP-4100M-VS/16E1T1/EOP
 MP-4100M-VS/6S/BIN/SSR
 MP-4100M-VS/6S/BIN/EMR
 MP-4100M-VS/6S/4E&M/PW
 MP-4100M-VS/6S/C37
 MP-4100M-VS/6S/C37/ST13L
 MP-4100M-VS/6S/8FXO/PW
 MP-4100M-VS/6S/8FXS/PW
 MP-4100M-VS/12S
 MP-4100M-VS/6S/8E1T1/PW
 MP-4100M-VS/6S/703/PW
 MP-4100M-VS/16E1T1/PW/M
 MP-4100M-VS/8E&M/PW/M
 MP-4100M-VS/8FXS/4E&M/M
 MP-4100M-VS-OCU-DP/4E&M

ORDERING OPTIONS

Some options are not supported by all models. Some option combinations are invalid or may require a minimum order. To determine the BOM for your application, please contact your local RAD partner.

Serial Ports	Default	No serial ports
	6S	6 serial ports
Other Ports	12S	12 serial ports
	4E&M	4 E&M voice ports
	8E&M	8 E&M voice ports
	8FXS	8 FXS voice ports
	8FX0	8 FX0 voice ports
	OCU-DP	2 OCU-DP – DDS ports
	8E1T1	8 E1/T1 links
	16E1T1	16 E1/T1 links
	703	8 G.703 64-kbps codirectional ports
	BIN/EMR	8 binary command ports with electromechanical relay output
Pseudowire	C37	2 C37.94 ports
	EOP	Ethernet over PDH support
	Default	Regular PW support
Switching	PW	Enhanced PW with ACR support
	M	Indicates Marvell-based switching in some modules without serial ports

OPTIONAL ACCESSORIES**CBL-SCS68/3/*/#/&**

Cable for converting each of the VS 68-pin SCSI connectors into 3 separate channel connectors with the physical interface specified.

Note: A separate cable is required for each of the 2/4 channel connectors.

Legend

*	Interface:	
	232	V.24/RS-232, 25-pin
	V35	V.35 interface, 34-pin
	V36	V.36/RS-449, 37-pin
	530	RS-530, 25-pin
	X21	X.21, 15-pin
#	Length (Default=2m / 6.5 ft):	
	3M	for 3m (9.8 ft)
	5M	for 5m (16.4 ft)
&	Connector:	
	F	female
	M	male

CBL-VS-VOICE

Cable for splitting each of the four RJ-12 connectors of FXS/FXO interface into two RJ-12 connectors intended for end-user equipment.

The default cable length is 1m/3.3 ft. For additional cable lengths available, contact your local sales representative

CBL-G703-8/RJ45

Splitter cable for splitting each 44-pin VS E1/T1 module connector to 8 E1 or 8 T1 balanced RJ-45 connectors

CBL-G703-8/RJ45/X

Splitter cross-cable for splitting each 44-pin VS E1/T1 module connector to 8 E1 or 8 T1 balanced RJ-45 connectors

CBL-G703-8/COAX

Splitter cable for splitting each 44-pin VS E1 module connector to 8 pairs of unbalanced BNC connectors

CBL-G703-8/OPEN

Open-ended cable with DB-44 connector on the Megaplex side for balanced E1 or T1 applications

CBL-VS-BIN

Open-ended cable with DB-44 connector on the Megaplex side for binary (alarm control) applications

All VS cables listed in this section are 2m (6.6 ft) long. For additional cable lengths available, see RAD catalog.

CBL-E1-SPLT

Cable for splitting each of the four RJ-45 connectors of the VS-6/703 module interface into two RJ-45 connectors intended for end-user equipment. The cable length is 1m/3.3 ft.

International Headquarters

24 Raoul Wallenberg St., Tel Aviv 6971923, Israel
Tel/Fax 972-52-4748272 | Fax 972-3-6498250
Email market@rad.com

North American Headquarters

900 Corporate Drive, Mahwah, NJ 07430, USA
Tel 201-529-1100 | Toll Free: 800-444-7234 | Fax: 201-529-5777
Email market@radusa.com



Your Network's Edge®

www.rad.com

464-121-06/25 Specifications are subject to change without prior notice. © 1988–2025 RAD Data Communications Ltd. The RAD name, logo, logotype, and the product names Airmux, IPmux, MiNID, MiCLK, Optimux, and SecFlow are registered trademarks of RAD Data Communications Ltd. All other trademarks are the property of their respective holders.