

# ONT-10

## High-Performance Enterprise and Business GPON ONT



- ITU G.984 compliant GPON ONT SFP
- Enterprise and business applications
- Enhanced QoS and multicast for video

ONT-10 is a G.984.2 (GPON) Optical Network Terminal (ONT) in a Small Form-factor Pluggable (SFP) enclosure. It is part of RAD's full GPON solution that includes both OLT (Optical Line Terminal) and ONT (Optical Network Terminal) platforms.

ONT-10 integrates a bidirectional optical transceiver function and a GPON MAC function. Plugged into a standard SFP port of a customer premise equipment (CPE), ONT-10 provides an asymmetric Gbps upstream 1.244/2.488 Gbps downstream GPON uplink to the CPE without requiring separate power supply.

ONT-10 supports a sophisticated ONT management system, including alarms, provisioning, DHCP and IGMP functions for a standalone IPTV solution at the ONT and can be managed from the OLT over the GPON using a G.988-compliant OMCI.

### MARKET SEGMENTS AND APPLICATIONS

RAD offers a series of advanced GPON ONT products designed for next-generation optical access networks delivering FTTH (Fiber-to-the-Home) and FTTB (Fiber-to-the-Building) services. The product line addresses the rapidly growing service provider needs for flexible, high-capacity fixed-line broadband solutions to support emerging video applications (e.g., mobile backhaul, MTU, VOD) in enterprise and residential deployments, aggregation of backhaul traffic from LTE cell sites, enterprise VPN services and SD-WAN networks based on the NFV paradigm.

### SERVICES

ONT-10 fits seamlessly into existing communications equipment, offering service providers a smooth upgrade to GPON. It vastly decreases the installation costs of deploying fiber access in MDUs and enables service providers to improve their revenue streams while decreasing OPEX.

# ONT-10

## High-Performance Enterprise and Business GPON ONT

### Specifications

#### GPON INTERFACE

<b>Connector</b>	Simplex SC/APC
<b>Wavelength</b>	1490 nm/1310 nm
<b>Range</b>	Up to 20 km
<b>Transmission</b>	Compliant with FSAN G.984.2 Integrated diplexer transceiver TC Layer GEM encapsulation mode Compliant with IEC-60825 Class 1 laser diode
<b>Optical Module</b>	Class B+
<b>Link Budget</b>	28 dB
<b>Optical Transmit Power</b>	+0.5 to +5 dBm
<b>Receiver Sensitivity</b>	-28 dBm
<b>Bit Rate</b>	Tx: 1244.16 Mbps Rx: 2488.32 Mbps
<b>Monitoring and Diagnostics</b>	Dying gasp notification support When OLT detects an anomaly, it issues a TX power shutdown command SFP MSA, digital diagnostics SFF-8472-compliant Subscriber location identifier (SLID) PON Link Status notification

Table 1. Pin Definitions

Pin	Description	Pin	Description
1	Module transmitter GND	11	Module receiver GND
2	ToD/Tx fault	12	RXD-
3	TX_disable	13	RXD+
4	Serial data line	14	Module receiver GND
5	Serial clock line	15	Module receiver 3.3V supply
6	Module absent	16	Module transmitter 3.3V supply
7	Dying gasp	17	Module transmitter GND
8	LOS	18	TXD+
9	1 PPS	19	TXD-
10	Module receiver GND	20	Module transmitter GND

#### MANAGEMENT

<b>Protocols</b>	OMCI, as per ITU-T G.988
<b>Options</b>	CLI

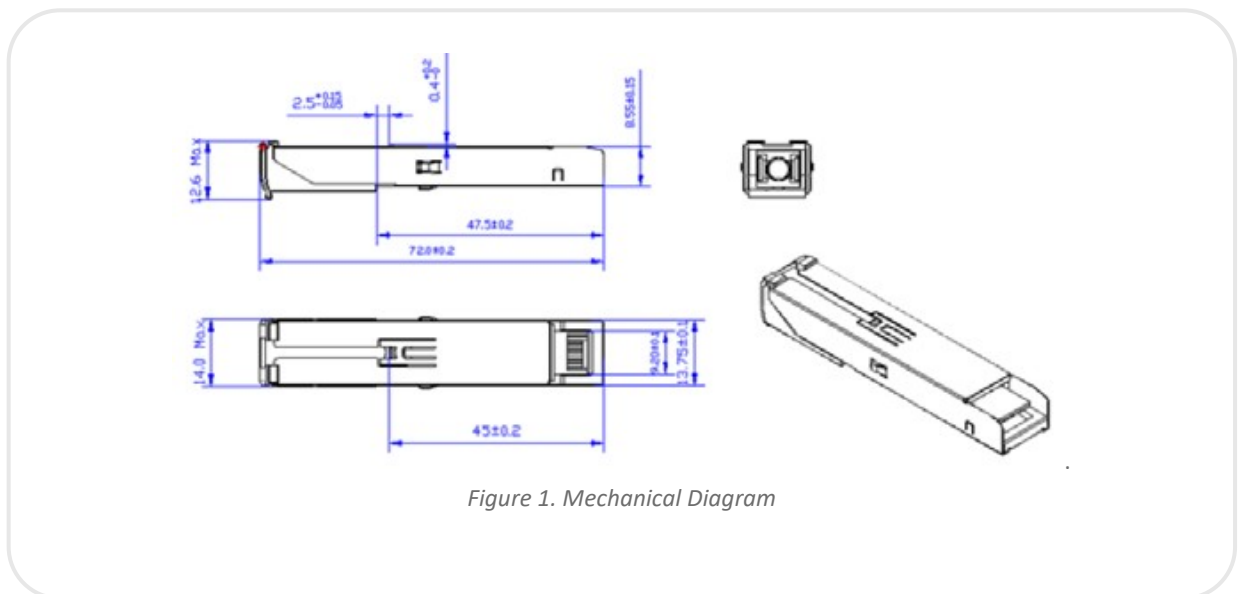

Figure 1. Mechanical Diagram

# ONT-10

## High-Performance Enterprise and Business GPON ONT

### GENERAL

#### Environment

Operating Temperature	-40°C to +85°C (-40°F to 185°F)
Humidity	5 to 95%, non-condensing
Compliance	RoHS

#### Power

Total Tx and Rx Supply Current	600 mA
Power Dissipation	2W

### Ordering

#### ONT-10

GPON optical network terminal SFP

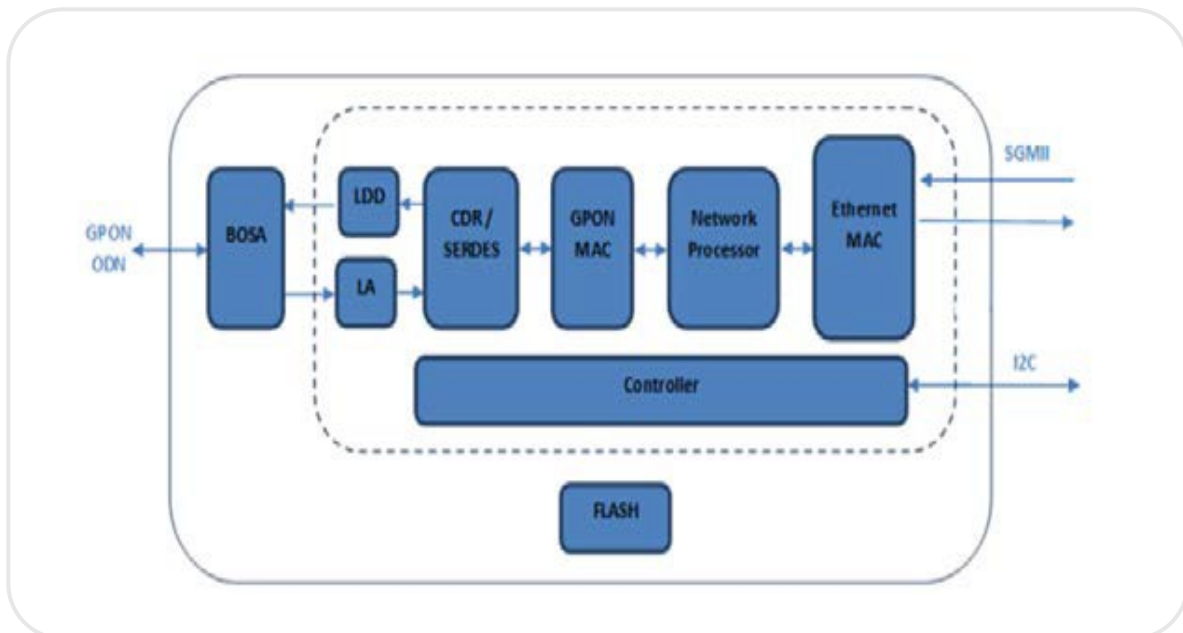

#### International Headquarters

24 Raoul Wallenberg St., Tel Aviv 6971923, Israel  
 Tel 972-3-6458181 | Fax 972-3-7604732  
 Email [market@rad.com](mailto:market@rad.com)

#### North American Headquarters

900 Corporate Drive, Mahwah, NJ 07430, USA  
 Tel 201-529-1100 | Toll Free: 800-444-7234 | Fax: 201-529-5777  
 Email [market@radusa.com](mailto:market@radusa.com)



Your Network's Edge®

[www.rad.com](http://www.rad.com)

556-108-10/21 (1.0) Specifications are subject to change without prior notice. © 2019–2021 RAD Data Communications Ltd. RAD products/technologies are protected by registered patents. To review specifically which product is covered by which patent, please see [ipr.rad.com](http://ipr.rad.com). The RAD name, logo, logotype, and the product names MINID, Optimux, Airmux, IPmux, and MiCLK are registered trademarks of RAD Data Communications Ltd. All other trademarks are the property of their respective holders.