

ETS-1-1G/L2

Ethernet Access Switches



- Advanced L2 functions
- Multicast support (IGMP snooping, MVR)
- Advanced security (multilayer ACLs, IP source guard, and dynamic ARP inspection)

MARKET SEGMENTS AND APPLICATIONS

New generation access switches provide end users connectivity to large-scale networks, small and medium business networks, and service provider networks, using Gigabit Ethernet interfaces.

The switches support VLANs, multicast groups, and advanced security.

Specifications

CAPACITY

Switching Capacity	See Table 1
Throughput	See Table 1
Max. Frame Size	See Table 1
MAC Address Table	8K
ACL Table	1.5K
RAM (DDR3)	256 MB
ROM (SPI Flash)	32 MB
VLAN Table	4K
Buffer Memory	512 kB

ETHERNET INTERFACES

Ports	See Table 1
Power over Ethernet (PoE)	PoE (15.4W per port): 802.3af PoE+ (30W per port): 802.3at
Features	Head-of-line blocking (HOL) protection Auto MDI/MDIX Flow control (IEEE 802.3X) Port mirroring RSPAN

MANAGEMENT

Control Port	RS-232 interface, RJ-45 connector
Protocols	SNTP (Simple Network Time Protocol) Traceroute LLDP (802.1ab) + LLDP MED SNMPv3 Management interface blocking Download and upload of configuration file via TFTP/SFTP Automated backup of configuration file via TFTP/SFTP
Access	Access control – privilege levels Local authentication IP addresses filtering for SNMP Flash file system Limiting of traffic to CPU CLI with password-protected access Password encryption Telnet client and server, SSH server Macro commands System log
IPv6	IPv6 host Dual-stack Static IPv4/IPv6 routes



ETS-1-1G/L2

Ethernet Access Switches

SECURITY

ACL	L2-L3-L4 ACL IPv6 ACL ACL based on: <ul style="list-style-type: none"> Physical port number IEEE 802.1p VLAN ID EtherType DSCP Protocol type TCP/UDP port number User defined bytes
TACACS+	TACACS+ clients Commands logging via TACACS+
RADIUS	RADIUS clients
Syslog	

Passwords	Password encryption Password recovery
Security Features	IP source guard Dynamic ARP inspection Traffic segmentation Debugging commands Rate limit of traffic to CPU MAC-based authentication, port security, static MAC entries Protection against unauthorized DHCP servers Support for several versions of configuration file DoS attacks prevention
SSL/SSH	SSH server/SSL
IEEE 802.1X	Port-based MAC-based

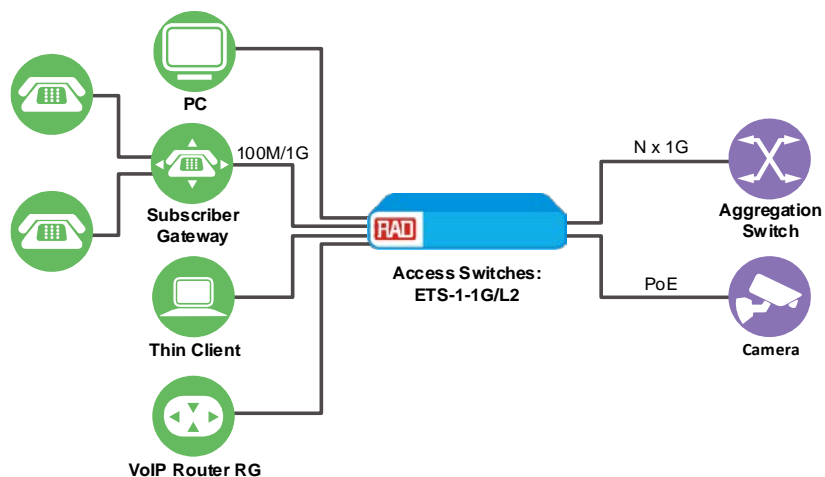

ETS-1-1G Ethernet Access Switches, Typical Application

ETS-1-1G/L2

Ethernet Access Switches

QUALITY OF SERVICE (QOS) AND RATE LIMITING

Class of Service	IEEE 802.1p Class of Service (CoS)
Bandwidth Control	8 egress queues per port
	Shaping
	Policing
	Storm control
	Scheduling algorithms: strict priority/Weighted Round Robin (WRR)
	ACL-based traffic classification
	ACL-based VLAN assignment
	IEEE 802.1p priority for management VLAN
	ACL-based CoS/DSCP mark assignment
	DSCP to CoS/CoS to DSCP remarking

LAYER 2

VLAN	802.1Q
	Q-in-Q
	Selective Q-in-Q (VLAN translation)
	MAC-based VLAN
	Protocol-based VLAN rules
MAC Table	Independent learning mode per VLAN
	MAC multicast support
	Configurable aging time of MAC addresses
	Static MAC entries
	MAC change events monitoring per ports
L2 Multicast	Multicast profiles
	Static Multicast groups
IGMP	IGMP snooping v1,2,3: 509 groups
	Port-based IGMP snooping Fast Leave
	IGMP querier
	IGMP proxy-report features
	IGMP authorization via RADIUS
MVR	
MLD	MLD snooping v1,2
DHCP	DHCP snooping
	DHCP clients filtering
	DHCP autoprovision
	DHCP relay (IPv4 support)
	DHCP relay option 82
	DHCP option 82
PPPoE	PPPoE intermediate agent
	PPPoE circuit-ID tag
BPDU	BPDU attacks prevention
	STP BPDU guard
	BPDU filtering

RESILIENCY

L2 Protection	STP (Spanning Tree Protocol, IEEE 802.1d)
	RSTP (Rapid Spanning Tree protocol, IEEE 802.1w)
	MSTP (Multiple Spanning Tree, IEEE802.1s)
	STP root guard
	STP loop guard
	STP BPDU guard
	BPDU filtering
	Spanning tree fast link option
	Layer 2 Protocol Tunneling
	Loopback Detection (LBD)
	Port isolation
	Storm control for different traffic (broadcast, multicast, unknown unicast)
Link Aggregation	8 groups
	Static LAG
	Dynamic LAG (LACP)
	LAG balancing algorithm

Table 1. Technical Features – ETS-1-1G/L2 Product Family

Specification	ETS-1-1G/L2/2S/8U/AC ETS-1-1G/L2/2S/8U/DC	ETS-1-1G/L2/2S/8P/ACW ETS-1-1G/L2/2S/8P/DC	ETS-1-1G/L2/4CMB/24U/AC ETS-1-1G/L2/4CMB/24U/DC	ETS-1-1G/L2/4CMB/24P/AC ETS-1-1G/L2/4CMB/24P/DC
Interfaces				
10/100/1000BASE-T (RJ-45) PoE/PoE+	-	8	-	24
10/100/1000BASE-T (RJ-45)	8	-	24	-
1000BASE-X (SFP)	2	2	-	-
Combo 10/100/1000BASE-T/100BASE-FX/1000BASE-X	-	-	4	4
Performance				
Switching Capacity	20 Gbps	20 Gbps	56 Gbps	56 Gbps
Throughput	up to 14.88 MPPS	up to 14.88 MPPS	up to 41.658 MPPS	up to 41.658 MPPS
Jumbo Frames - max. packet size	10 000 bytes	10 000 bytes	10 240 bytes	10 240 bytes
Physical and Power				
Dimensions (WxDxH)	310x44x177	430x178x44 mm	430x178x44 mm	430x178x44 mm
Weight	1.72 kg	2.69 kg	2.35 kg	2.35 kg
Power Supply	AC: 100–250 VAC, 60/50 Hz DC: 18–72 VDC	AC: 100–250 VAC, 60/50 Hz DC: 18–72 VDC	AC: 110–250 VAC, 60/50 Hz DC: 18–72 VDC	AC: 170–264 VAC, 60/50 Hz DC: 18–72 VDC
Power Consumption	10W	24W (not including PoE)	25W	70W (not including POE)
POE Maximum Power	-	256W	-	370W
Hardware support for Dying Gasp	no	no	yes (AC only)	yes (AC only)

MONITORING AND DIAGNOSTICS

Diagnostic	Ping (IPv4/IPv6 support)
	Virtual Cable Testing (VCT)
	Optical transceiver diagnostics
Monitoring	Statistics on interfaces
	CPU utilization monitoring per task and per queue
	RAM utilization monitoring
	Temperature monitoring
	TCAM utilization monitoring
OAM/CFM	802.3ah Ethernet link OAM
	Dying gasp
	802.3ah Unidirectional Link Detection (UDLD)

GENERAL

Environment

Operating Temperature	ETS-1-1G/L2/2S/8U/AC: -20 to +60°C (-4 to 140°F) Other models: -20 to +50°C (-4 to 122°F)
Storage Temperature	-40 to 70°C (-40 to 158°F)
Cooling	Passive 10% to 95%

Operational and Storage Relative Humidity	Non-condensing
--	----------------

Physical and Power

See Table 1

ETS-1-1G/L2

Ethernet Access Switches

Ordering

The information below represents examples of supported configurations. For additional configuration options, please contact your local RAD partner.

ETS-1-1G/L2/2S/8U/AC

ETS-1-1G/L2/2S/8U/DC

ETS-1-1G/L2/2S/8P/ACW

ETS-1-1G/L2/2S/8P/DC

ETS-1-1G/L2/4CMB/24U/AC

ETS-1-1G/L2/4CMB/24U/DC

ETS-1-1G/L2/4CMB/24P/AC

ETS-1-1G/L2/4CMB/24P/DC

ORDERING OPTIONS

Some options are not supported by all models. Some option combinations are invalid or may require a minimum order. To determine the BOM for your application or any standard compliance-related information, please contact your local RAD partner.

Ethernet Ports	2S	2 x 1000BASE-X (SFP) ports
	8U	8 x 10/100/1000BASE-T ports
	8P	8 x 10/100/1000BASE-T (PoE/PoE+) ports
	4CMB	4 COMBO ports of 10/100/1000BASE-T/100BASE-FX/1000BASE-X
	24U	24 10/100/1000 Base-T(X) ports
	24P	24 ports of 10/100/1000BASE-T POE+
Power Supply	AC/ACW	AC power supply
	DC	48 VDC

OPTIONAL ACCESSORIES

CBL-SGW-RJ45-D9-F-6FT

RJ-45 to DB-9 console cable

International Headquarters

24 Raoul Wallenberg St., Tel Aviv 6971923, Israel
Tel/Fax 972-52-4748272 | Fax 972-3-6498250
Email market@rad.com

North American Headquarters

900 Corporate Drive, Mahwah, NJ 07430, USA
Tel 201-529-1100 | Toll Free: 800-444-7234 | Fax: 201-529-5777
Email market@radusa.com



Your Network's Edge®

www.rad.com

751-105-06/24 (10.3) Specifications are subject to change without prior notice. © 1988–2024 RAD Data Communications Ltd. The RAD name, logo, logotype, and the product names Airmux, IPmux, MiNID, MiCLK, Optimux, and SecFlow are registered trademarks of RAD Data Communications Ltd. All other trademarks are the property of their respective holders.