

ETS-1-100G

Data Center Switches

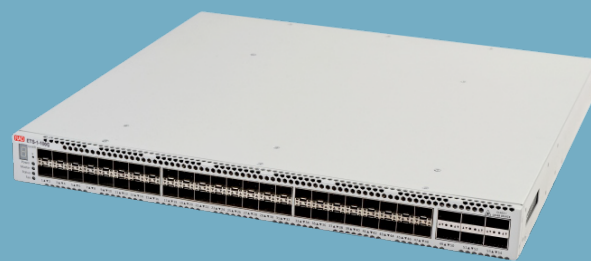

- High performance (up to 6.4 Tbps)
- Non-blocking architecture
- Front-to-back cooling
- Stacking up to eight devices
- Hot-swappable redundant power supplies

The ETS-1-100G switches are high performance devices that can be used as aggregation or transport switches in carrier networks and as top-of-rack or end-of-row switches for data centers.

The ETS-1-100G family features a variety of ports operating either at up to 40 Gbps (QSFP+) or 100 Gbps (QSFP28) upstream, and 1 Gbps (SFP)/10 Gbps (SFP+) downstream. 100G ports can split into 4 x 25 Gbps using breakout cables, such as DAC (Direct Attach Cable) or AOC (Active Optical Cable).

The non-blocking architecture guarantees lossless packet forwarding at wire speed with minimum and predictable delays for all types of traffic.

Specifications

CAPACITY

Switching Capacity	See Table 1
Throughput on 64-byte packets	See Table 1
Buffer Memory	See Table 1
MAC Address Table	See Table 1
RAM	See Table 1
ROM	See Table 1
VLAN Table Size	4094
ARP Table Size	See Table 1
Jumbo Frames	10240 bytes
Link Aggregation Groups (LAG)	See Table 1
QoS	8 egress queues per port
Stacking	See Table 1

ETHERNET INTERFACES

Ports	See Table 1
Features	Head-of-line blocking (HOL) protection
	Auto MDI/MDIX
	Flow control (IEEE 802.3X)
	Jumbo frames
	Stacking
	Back pressure
	Port mirroring

MANAGEMENT

Access Options	Web-based interface
	Command Line Interface (CLI)
Control Port	RS-232 interface, RJ-45 connector
Protocols	SNTP (Simple Network Time Protocol)
	Traceroute
Management Functions	Configuration file download and upload via TFTP/SCP
	SNMP
	LLDP (802.1ab)
	Management ACL
	Management interface blocking
Access Control	Access control – privilege levels
	Local authentication
	IP addresses filtering for SNMP
	Flash File System
	Limiting of traffic to CPU
	Password encryption
	Password recovery
	Telnet server
	SSH server
	SSL
	CLI command logging
	System log
	Macro commands
IPv6	IPv6 host
	IPv6/IPv4 compatibility

ETS-1-100G

Data Center Switches

SECURITY

ACL	L2-L3-L4 ACL Time-based ACL IPv6 ACL Management ACL ACL based on: <ul style="list-style-type: none"> Physical port number IEEE 802.1p VLAN ID EtherType DSCP Protocol type TCP/UDP port number
TACACS+	TACACS+ clients
RADIUS	RADIUS clients
Security Features	IP source guard sFlow MAC address limitation Guest VLAN NetBIOS/NetBEUI filtering Dynamic ARP inspection Traffic segmentation Debugging commands MAC-based authentication Static MAC entries DoS attacks prevention
IEEE 802.1X	IEEE 802.1x port-based interface authentication

QUALITY OF SERVICE (QOS) AND RATE LIMITING

Class of Service	IEEE 802.1p Class of Service (CoS)
Bandwidth Control	Shaping Policing Scheduling algorithms: Strict Priority/Weighted Round Robin (WRR) ACL-based traffic classification QoS statistics Broadcast Storm Control Three marking colors

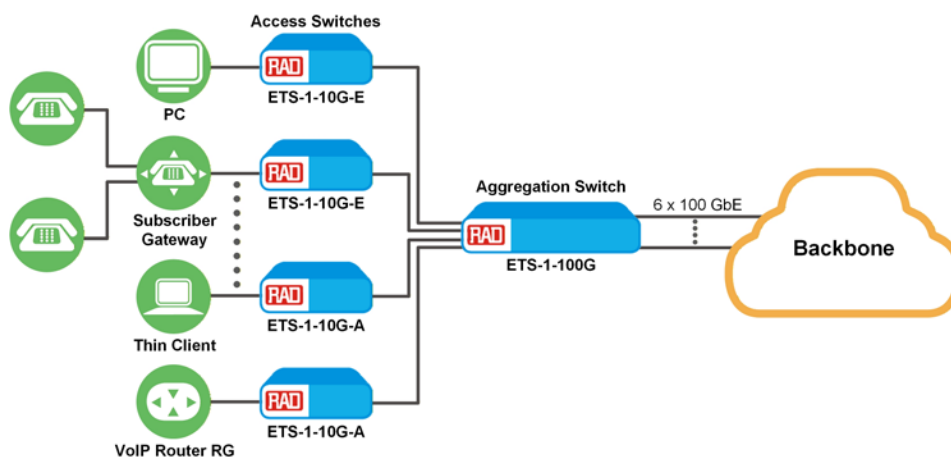

ETS-1-100G Aggregation Switches

LAYER 2

VLAN	802.1Q
	Q-in-Q
	Selective Q-in-Q (VLAN translation)
	GVRP
	Voice VLAN
	Support for L2VPN services
MAC Table	Independent learning mode per VLAN
	MAC multicast support
	Configurable aging time of MAC addresses
	Static MAC entries
	MAC flapping logging
L2 Multicast	Multicast profiles
	Static multicast groups
IGMP	IGMP snooping v1,2,3
	Port/host-based IGMP snooping fast leave
	IGMP querier
	IGMP authorization via RADIUS
MLD	MLD snooping v1,2
DHCP	DHCP snooping
	DHCP clients filtering
	DHCP auto provisioning
	DHCP relay (IPv4 support)
	DHCP options 12 and 82
BPDU	BPDU attack prevention
	STP BPDU guard
	BPDU filtering

IP ADDRESSING AND ROUTING

Addressing	IPv4 and IPv6
	IP unnumbered
Routing Protocols	Dynamic routing protocols
	RIP
	OSPFv2, OSPFv3
	BGP (requires license, see Ordering)
	IS-IS
	VRRP
	PIM SM, IGMP proxy
	BFD
	VRF lite
	Address Resolution Protocol (ARP)
Routing Technologies	Static IP routes
Services	Support for L3VPN services

RESILIENCY

L2 Protection	STP (Spanning Tree Protocol, IEEE 802.1d)
	RSTP (Rapid Spanning Tree protocol, IEEE 802.1w)
	MSTP (Multiple Spanning Tree, IEEE802.1s)
	STP root guard
	Spanning tree fast link option
	Loopback Detection (LBD)
	ERPS (G.8032v2)
	PVSTP+
	RPVSTP+
	Flex-Link
Link Aggregation	Link Aggregation Groups (LAG)
	Dynamic LAG (LACP)
	Multi-switch Link Aggregation Group (MLAG)
	LAG Balancing Algorithm

MONITORING AND DIAGNOSTICS

Diagnostics	Ping (IPv4/IPv6 support)
	Optical transceiver diagnostics
Monitoring	Statistics on interfaces
	Remote monitoring RMON/SMON
	Task- and traffic type-based CPU utilization monitoring
	IPFIX
	Green Ethernet
	Temperature monitoring
	TCAM monitoring
	Syslog
OAM	802.3ah Ethernet Link OAM
	802.3ah Unidirectional Link Detection

GENERAL

Environment

See Table 1

Physical and Power

See Table 1

Table 1. Technical Features

Specification	ETS-1-100G/6QP28/24SP/DPS	ETS-1-100G/6QSPP/48SP/DPS	ETS-1-100G/32QP28/2SP/DPS
Interfaces			
1000BASE-X (SFP)/10GBASE-R (SFP+)	24	48	2
40GBASE-R (QSFP+)/100GBASE-R (QSFP28)	6	6	32
10/100/1000BASE-T (OOB)	1	1	1
USB 2.0	1	1	1
Console port RS-232 (RJ-45)	1	1	
Performance			
Switching capacity, Tbps	1.68	2.16	6.4
MAC Table	65536	65536	131072/262144**
L2 Multicast Groups	4092	4092	2046
Buffer memory, MB	12	12	24
Throughput for 64 bytes, MPPS	878.3	1028.5	1995
RAM	8 GB (DDR4)	8 GB (DDR4)	8 GB (DDR4)
ROM	8 GB (embedded uSSD)	8 GB (embedded uSSD)	8 GB (embedded uSSD)
SQinQ rules	1320 (ingress), 1320 (egress)	1320 (ingress), 1320 (egress)	1320 (ingress), 1320 (egress)
MAC ACL rules	6070	6070	5089
ARP table	32701	32701	65527/98237**
IPv4/IPv6 ACL rules*	6070/3035	6070/3035	5089/2544**
L3 IPv4 Unicast routes*	32735	32735	292000/16000**
L3 IPv6 Unicast routes*	8181	8181	73000 /4000 **
L3 IPv4 Multicast routes*	163661	163661	146000/8000**
L3 IPv6 Multicast routes*	4088	4088	36500/2000**
VRRP routers	127	127	127
Maximum size of ECMP groups	64	64	64
VRF number (including default VRF)	251	251	251
L3 interfaces	2050	2050	2050
Maximum number of VXLAN	4093	4093	4093
Stacking	Up to 8 devices	Up to 8 devices	Up to 8 devices
Link Aggregation Groups (LAG)	128, up to 32 ports per LAG	128, up to 8 ports per LAG	128, up to 8 ports per LAG
Dying Gasp Support	no	no	no
Quality of Service (QoS)	8 egress queues per port		
Physical and Power			
Dimensions (WxHxD)	440 x 44 x 321 mm	440 x 44 x 447 mm	440 x 44 x 534 mm
Weight	6.36 kg	8.7 kg	11.8 kg
Power supply	AC: 100–240V, 50–60 Hz DC: 36–72V Up to two AC/DC hot-swappable power sources	AC: 176–240V, 50–60 Hz DC: 36–72V Up to two AC/DC hot-swappable power sources	AC: 100–240 V AC, 50–60 Hz DC: 36–72V Up to two AC/DC hot-swappable power sources
Maximum power consumption, W	150	170	400
Input current	0.5–1.7A for AC 2-4A for DC	0.5-1.0A for AC 2-4.5A for DC	4–1.67 A for AC 8–6.67 A for DC
Operating temperature	from 0 to +45°C		
Storage temperature	from -50 to +70°C		
Operating humidity	no more than 80%		
Cooling	Front-to-Back, 4 fans	Front-to-Back, 4 fans	Front-to-Back, 5 dual fans
*IPv4/IPv6 Unicast/Multicast routes share hardware resources.			
**Maximum value in mid-I3-mid-I2 mode/Maximum value in min-I3-max-I2 mode			

ETS-1-100G

Data Center Switches

Ordering

ETS-1-100G/6QP28/24SP/DPS

L3 Ethernet Switch, 1x10/100/1000BASE-T (OOB), 24x1000BASE-X (SFP)/10GBASE-R (SFP+), 6x40GBASE-R (QSFP+) / 100GBASE-R (QSFP28), 1xUSB 2.0, dual PS slots (PSs not included)

ETS-1-100G/6QSPP/48SP/DPS

L3 Ethernet Switch, 1x10/100/1000BASE-T (OOB), 48x1000BASE-X(SFP)/10GBASE-R (SFP+), 6x40GBASE-R (QSFP+) /100GBASE-R (QSFP28), 1xUSB 2.0, dual PS slots (PSs not included)

ETS-1-100G/32QP28/2SP/DPS

L3 Ethernet Aggregation switch, 1 × 10/100/1000BASE-T (OOB), 32 × 40GBASE-R (QSFP+)/100GBASE-R (QSFP28), 2 × 10GBASE-R (SFP+), 1 × USB 2.0, dual PS slots (PSs not included)

OPTIONAL ACCESSORIES

ETS-1-BGP-LIC

License for using BGP protocol

ETS-1-MPLS-LIC

License for using MPLS protocol

CBL-SGW-RJ45-D9-F-6FT

RJ-45 to DB-9 console cable

Hot Swappable Power Supplies

Separately ordered per needed quantity (1 or 2) and type (DC or AC)

Device	AC Power Supply Module	DC Power Supply Module
ETS-1-100G/ 6QP28/24SP/DPS	ETS-1-10G-PS/ AC220/165W	ETS-1-100G-PS/ DC48/160W
	100-240 VAC, 165W	36-72 VDC, 160W
ETS-1-100G/ 6QSPP/48SP/DPS	ETS-1-100G-PS/ AC220/350W	ETS-1-100G-PS/ DC48/350W
	200-240 VAC, 350W	36-72 VDC, 350W
ETS-1-100G/ 32QP28/2SP/DPS	ETS-1-100G-PS/ AC220/600W	ETS-1-100G-PS/ DC48/600W
	200-240 VAC, 600W	36-72 VDC, 600W

International Headquarters

24 Raoul Wallenberg St., Tel Aviv 6971923, Israel
Tel/Fax 972-52-4748272 | Fax 972-3-6498250
Email market@rad.com

North American Headquarters

900 Corporate Drive, Mahwah, NJ 07430, USA
Tel 201-529-1100 | Toll Free: 800-444-7234 | Fax: 201-529-5777
Email market@radusa.com



Your Network's Edge®

www.rad.com

751-106-03/26 (6.6) Specifications are subject to change without prior notice. © 1988–2026 RAD Data Communications Ltd. The RAD name, logo, logotype, and the product names Airmux, IPmux, MiNID, MiCLK, Optimux, and SecFlow are registered trademarks of RAD Data Communications Ltd. All other trademarks are the property of their respective holders.