

SecFlow-2

Ruggedized SCADA-Aware Ethernet Switch/Router



- Compact ruggedized Ethernet switch/router with up to 16x10/100BASE-T, and 2x100/1000BASE-FX ports with optional PoE for deployment in harsh industrial environments
- Advanced security package, including IEEE 802.1X port-based Network Access Control, L-2/3/4 ACL for incoming traffic, and L-2/3 VPN with IPsec
- Integrated serial interface with protocol gateway and tunneling functionality
- Ethernet switching, IP routing with integrated VPN and link protection per ITU-T G.8032, with optional cellular 2G/3G/HSPA+/4G (LTE) uplink for maximum service continuation
- IEC61850 design*
- IPsec VPN over cellular and fiber with X.509 certificates
- Wide range of AC or DC power input options

SecFlow®-2 is a ruggedized Ethernet switch/router with a unique built-in packet processing SCADA-aware engine to fit the mission-critical industrial applications.

SecFlow-2 features two Gigabit Ethernet ports, up to 16 Fast Ethernet ports, and serial ports for legacy services. The device is designed for installation under harsh environmental conditions. It enables DIN-rail mount, ensures IP30 protection level, wide temperature operating range (-40 to 70°C) without fans, EMI immunity (IEC61850-3, IEEE1613 and EN50121-4).

SecFlow-2 complies with the IEC 61850 standard to provide Intelligent Electronic Device (IED) solutions for electrical substations automation.

Additionally, SecFlow-2 is equipped with the serial interfaces for connectivity between legacy RTUs and new IP-based IEDs. SecFlow-2 gateway converts legacy DNP3-Serial to DNP3-TCP, IEC-101 protocol to IP-based IEC-104, and Modbus RTU to Modbus TCP, enabling seamless IP SCADA communication to both old and new RTUs. This provides a single box solution for multi-service applications and smooth migration to all-IP networks.

MARKET SEGMENTS AND APPLICATIONS

SecFlow-2 addresses the following markets:

- Utility installations (electricity, water, gas and oil)
- Intelligent transportation (highway, railway)
- Manufacturing facilities (chemical, food industry)
- Military and defense applications (HLS, safe city)

INTEROPERABILITY

SecFlow-2 is compatible with SecFlow-1, SecFlow-1v and SecFlow-4. In addition, it operates with RAD's Airmux broadband wireless multiplexer, providing PoE feeding to the Airmux outdoor units (see [Ordering](#)).

ETHERNET

Flexible QoS techniques ensure differentiated service end-to-end delivery.

SecFlow-2 utilizes the following traffic management methods: strict priority, Weighted Round Robin (WRR), ingress policing and egress traffic shaping.

ROUTER AND VPN SERVICES

SecFlow-2 features static routing, OSPF, RIPv2, VRRP, NAT.

In addition, the device features a VPN gateway with two operation modes:

- Inter-site connectivity, using IPsec tunnels
- Remote user access, using SSH

Inter-site VPN, based on GRE tunnels over an IPsec encrypted link and DMVPN, ensures L2/L3 Ethernet networks sites' transparent connection.

For remote access, SecFlow-2 uses an SSH-encrypted tunnel with user authentication and specific access authorizations.



SecFlow-2

Ruggedized SCADA-Aware Ethernet Switch/Router

OAM

SecFlow-2 provides the following Ethernet OAM types:

- Single-segment (link) OAM according to IEEE 802.3-2005 (formerly 802.3ah) for remote management and fault indication
- End-to-end connectivity OAM, based on IEEE 802.1ag, to monitor Ethernet services proactively and guarantee the contracted SLA
- End-to-end fault, service, and performance monitoring based on ITU-T Y.1731

RESILIENCY

SecFlow-2 supports Ethernet protection ring according to G.8032, enabling fast failure detection and switchover.

Traditional resiliency protocols, such as RSTP (Rapid Spanning Tree Protocol) and MSTP (Multiple Spanning Tree Protocol) per IEEE 802.1D, are also supported.

Link aggregation is performed according to IEEE 802.3ad. LACP aggregates the point-to-point links operating at the same data rate. This enables SecFlow-2 to take advantage of increased bandwidth.

MANAGEMENT AND SECURITY

The device can be managed via:

- RADview, RAD's carrier-class NMS for Windows and Linux
- Standalone Shelf View

SecFlow-2 also supports a variety of access protocols including Telnet, SSH, SNMPv3, and TFTP/SFPT.

Specifications

CAPACITY

Throughput

Line rate L2/L3 switching throughput for hardware-based router

Switching

Switching latency below 10 μ sec

Max. Number of MAC Addresses

16K

Max. Number of VLANs

4K

Internal Memory

1 GB DRAM

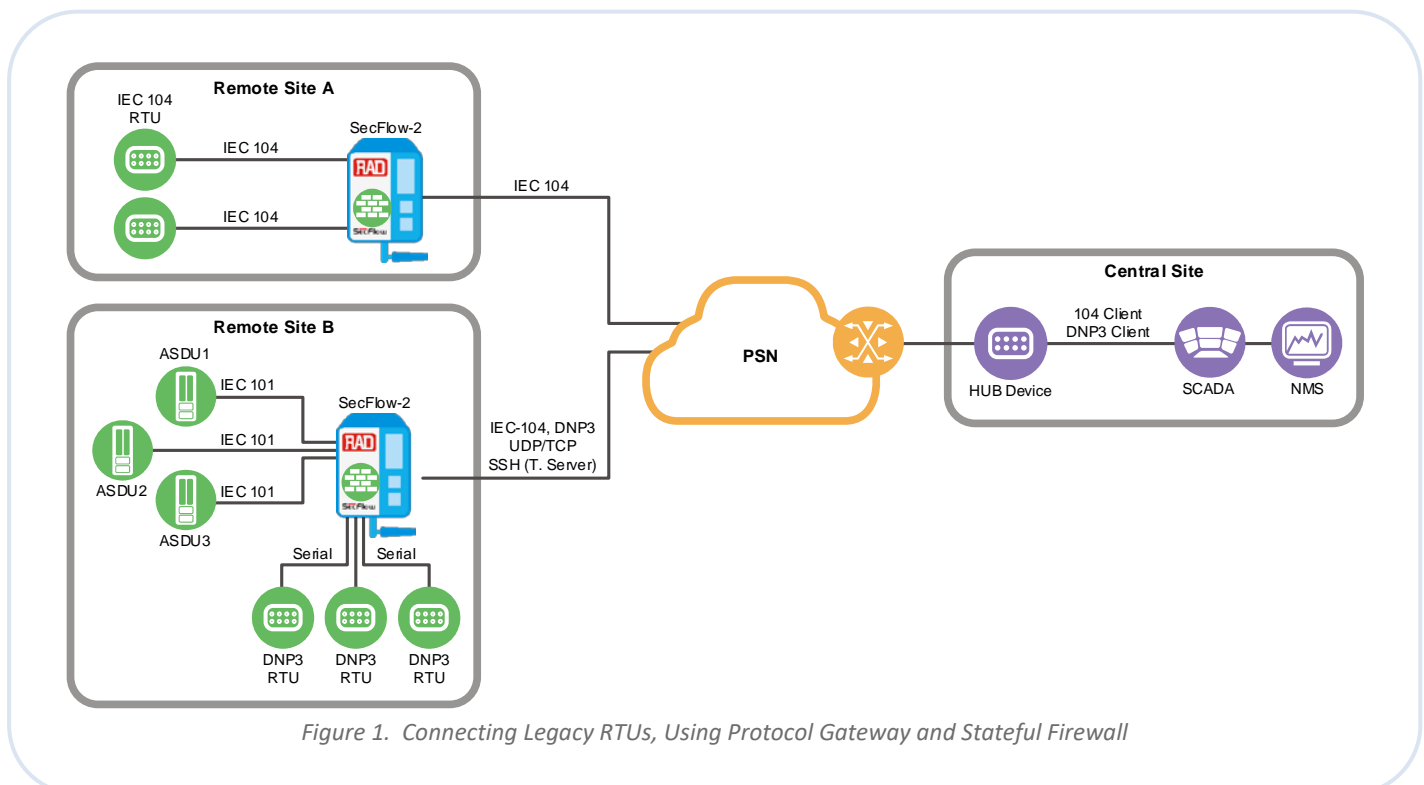

SecFlow-2

Ruggedized SCADA-Aware Ethernet Switch/Router

ETHERNET INTERFACES

Gigabit Ethernet Port

2 x SFP sockets

Fiber SFP: 100BASE-FX/1000BASE-SX/LX

Copper SFP: 100/1000BASE-TX

Fast Ethernet Port

8 x 10/100BASE-T RJ-45 ports

16 x 10/100BASE-T RJ-45 ports

8 x 10/100BASE-T RJ-45 + 8 x 100BASE-FX SFP ports

Copper ports are available with several PoE ordering options

Autonegotiation IEEE 802.3ab

Max Frame Size

9216 Bytes

POE

Compliance

IEEE 802.3af-2003 up to 15W per port

IEEE 802.3at-2009 up to 30W per port

SERIAL INTERFACES

Up to 4 x RS-232 ports

Up to 2 x RS-485 ports

Transparent tunneling of serial streams

SCADA protocol gateway – serial over IP

Terminal Server

CELLULAR

Dual SIM GPRS/UMTS/LTE cellular modem

ETHERNET

VLAN segregation per IEEE 802.1q

VLAN tagging according to L2–L4 headers

User policy for traffic type

L2 multicast with guaranteed QoS

IGMP Snooping (v1, v2, v3) for traffic optimization

ROUTER

Static Routing, OSPF, BGP, VRF, RIPv2 Routing, VRRP, NAT

MANAGEMENT

Control Port

RS-232

USB Port

Local USB port for emergency boot

Management Capabilities

Command-line interface with password protected access and authorization levels,

Telnet/SSH, SNMPv1, SNMPv2, SNMPv3, RADview-EMS, SFTP

Tools

RADIUS, TACACS+

Conditioned/scheduled system reboot

Remote management and upgrade

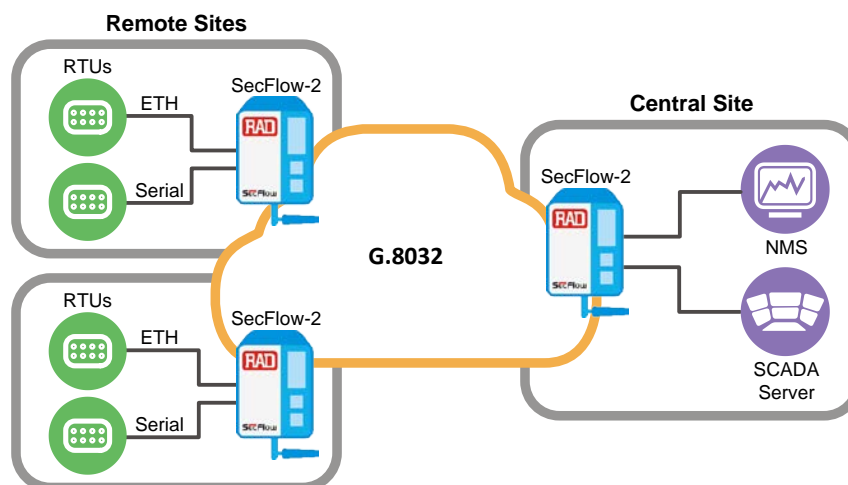

Figure 2. Operational WAN for CI

TFTP/SFTP Client

Syslog

LLDP discovery per IEEE802.1AB

DHCP client

DHCP relay, option 82

TIMING

NTP v2

Date/Time Setting

SNTP

RESILIENCY

Ethernet Ring

Ethernet ring per ITU-T G.8032v2

IEEE 802.1s MSTP

IEEE 802.1w RSTP

Link Aggregation

LAG with LACP per IEEE 802.3ad

DIAGNOSTICS

Alarms

LEDs, including Alarm and status interfaces

Dry contact 2-in and 2-out

SECURITY

Enable/disable port

Port-based authentication per IEEE 802.1X

Protection against DoS attacks

L2, L3, L4 Access Lists

OS Image Protection

Industrial VPN Agent

Remote access using SSH tunnel

Layer 2 GRE Transparent Ethernet Bridging

Layer 3 mGRE DMVPN

IPsec VPN

- Policy-based
- Route-based
- IKE, AES or 3DES encryption
- Dynamic key exchange
- X.509 certificates, IPsec CRL server, IPsec CA server

GENERAL

Compliance

Safety regulations:

- UL 60950-1
- IEC/EN 60950-1

EMC regulations:

- EN 55032 Class A
- FCC Class A

Physical

Height: 148 mm (5.6 in)

Width: 72 mm (2.8 in)(8-port DC),
95 mm (3.7 in)(16-port DC),
151.5 mm (5.96 in)(AC)

Depth: 123.0 mm (4.8 in)

Weight: 1.7 kg (3.75 lb)(8-port DC),
2.07 kg (4.56 lb)(16-port AC)

Power

AC: 100–240 VAC

DC: 48VDC (20–60 VDC), 24VDC (20–32 VDC), 12VDC (10–18 VDC), 110VDC (94–132 VDC)

Power Consumption

15W (regular operation / no PoE)

48 VDC: 135W (120W for PoE)*

AC-powered units: 135W or 255W (120W or 240W for PoE)

* **Note:** 48VDC options must be powered with 46VDC or 52VDC and up, to support PoE or PoE+, respectively.

Environment

Storage Temperature: -40 to 85°C (-40 to 185°F)

Operating Temperature**: -40 to 70°C (-40 to 158°F)

Humidity: up to 90%

Operating temperature of SF-AC-48VDC-120W power unit:

- Without POE (power less than 15W):
-20 to 70°C (-4 to 158°F)
- With POE: -20 to 60°C (-4 to 140°F)

Rugged enclosure – fanless, IP 30-rated

Substation automation per IEC 61850-3/IEEE1613 EMI**

Vibration and shock resistance per EN50121-4

****Note:** The operating temperature range and availability of some certifications can vary depending on the ordering option. For more information, refer to the SecFlow-2 Installation and Operation Manual.

Ordering

RECOMMENDED CONFIGURATIONS

SF2/B/AC/2GE8UTP

Basic option with Ethernet features, 90–240 VAC power supply, 2×GbE SFP and 8×10/100BASE-T Ethernet ports

SF2/B/AC/2GE16UTP/POE240W

Basic option with Ethernet features, 90–240 VAC power supply, 2×GbE SFP and 16 x 10/100BASE-T Ethernet ports, PoE on 8 x 10/100BASE-T ports up to 240W

SF2/B/48VDC/2GE8UTP/POE

Basic option with Ethernet features, 48 VDC (20–60 VDC) power supply, 2 x GbE SFP and 8 x 10/100BASE-T Ethernet ports, Power over Ethernet on 8 x 10/100BASE-T ports

SF2/B/48VDC/2GE16UTP/POE

Basic option with Ethernet features, 48 VDC (20–60 VDC) power supply, 2 x GbE SFP and 16 x 10/100BASE-T Ethernet ports, Power over Ethernet on 8 x 10/100BASE-T ports

SF2/B/48VDC/2GE16UTP/POE240W

Basic option with Ethernet features, 48 VDC (20–60 VDC) power supply, 2 x GbE SFP and 16 x 10/100BASE-T Ethernet ports, Power over Ethernet on 8 x 10/100BASE-T ports up to 240W

SF2/B/48VDC/2GE8UTP8SFP/POE

Basic option with Ethernet features, 48 VDC (20–60 VDC) power supply, 2 x GbE SFP, 8 x 10/100BASE-T and 8 x 100BASE-FX ports, Power over Ethernet on 8 x 10/100BASE-T ports

SF2/B/110VDC/2GE8UTP8SFP

Basic option with Ethernet features, 110 VDC (94–132 VDC) power supply, 2 x GbE SFP, 8 x 10/100BASE-T, and 8 x 100BASE-FX Ethernet ports

SF2/S/48VDC/2GE8UTP

Routing with secured VPN and serial gateway, 48 VDC (20–60 VDC) power supply, 2 x GbE SFP and 8 x 10/100BASE-T Ethernet ports

SF2/S/48VDC/2GE8UTP8SFP

Routing with secured VPN and serial gateway, 48 VDC (20–60 VDC) power supply, 2 x GbE SFP, 8 x 10/100BASE-T and 8 x 100BASE-FX Ethernet ports

SF2/S/48VDC/2GE16UTP

Routing with secured VPN and serial gateway, 48 VDC (20–60 VDC) power supply, 2 x GbE SFP and 16 x 10/100BASE-T Ethernet ports

SF2/S/24VDC/2GE8UTP

Routing with secured VPN and serial gateway, 24 VDC (20–32 VDC) power supply, 2 x GbE SFP and 8 x 10/100BASE-T Ethernet ports

SF2/S/24VDC/2GE8UTP8SFP

Routing with secured VPN and serial gateway, 24 VDC (20–32 VDC) power supply, 2 x GbE SFP, 8 x 10/100BASE-T Ethernet ports, and 8 x 100BASE-FX Ethernet ports

SF2/S/12VDC/2GE8UTP

Routing with secured VPN and serial gateway, 12 VDC (10–18 VDC) power supply, 2 x GbE SFP and 8 x 10/100BASE-T Ethernet ports

SF2/S/AC/2GE8UTP

Routing with secured VPN and serial gateway, 90–240 VAC power supply, 2 x GbE SFP and 8 x 10/100BASE-T Ethernet ports

SF2/S/AC/2GE16UTP

Routing with secured VPN and serial gateway, 90–240 VAC power supply, 2 x GbE SFP and 16 x 10/100BASE-T Ethernet ports

| SUFFIX | Optional Power over Ethernet (PoE) + Interface |
|---|--|
| SF2/S/48VDC/2GE8UTP/* | |
| Routing with secured VPN and serial gateway, 48 VDC (20–60 VDC) power supply, 2×GbE SFP and 8x10/100BASE-T Ethernet ports | |
| * POE/CEL | PoE on 8 x 10/100BASE-T ports up to 120W, GPRS/UMTS cellular modem |
| POE/RS232 | PoE on 8 x 10/100BASE-T ports up to 120W, 4 x RS-232 ports |
| POE/LTEEU | PoE on 8 x 10/100BASE-T ports up to 120W, LTE cellular modem with European bands |
| RS232 | 4 x RS-232 ports |
| RS232/CEL | 4xRS-232 ports, GPRS/UMTS cellular modem |
| RS232/LTEEU | 4xRS-232 ports, LTE cellular modem with European bands |
| POE/RS232/CEL | PoE on 8 x 10/100BASE-T ports up to 120W, 4 x RS-232 ports, GPRS/UMTS cellular modem |
| POE/RS232/LTEEU | PoE on 8 x 10/100BASE-T ports up to 120W, 4 x RS-232 ports, LTE cellular modem with European bands |
| POE2AM | PoE on 2 x 10/100BASE-T for RAD's Airmux and standard PoE for the remaining 6 x 10/100BASE-T ports |
| POE4AM/RS232 | PoE on 4 x 10/100BASE-T for RAD's Airmux and standard PoE for the remaining 4 x 10/100BASE-T ports, 4 x RS-232 ports |
| POE2AM/RS232/CEL | PoE on 2 x 10/100BASE-T for RAD's Airmux and standard PoE for the remaining 6 x 10/100BASE-T ports, 4 x RS-232 ports, GPRS/UMTS cellular modem |
| POE/RS232/HSPAP | PoE on 8 x 10/100BASE-T ports up to 120W, 4 x RS-232 ports, high-speed packet access modem, 3.5G |
| RS232/HSPAP | 4 x RS-232 ports, high-speed packet access modem, 3.5G |
| RS232/LTEVZ | 4 x RS-232 ports, LTE cellular modem with NA Verizon bands |
| RS232/LTENA | 4 x RS-232 ports, LTE cellular modem with North American bands |
| POE/HSPAP | PoE on 8 x 10/100BASE-T ports up to 120W, high-speed packet access modem, 3.5G |
| POE/RS232/LTEVZ | PoE on 8 x 10/100BASE-T ports up to 120W, 4 x RS-232 ports, LTE cellular modem with NA Verizon bands |
| 4RSM/LTEEU | 2 x RS-232 and 2 x RS-485 ports, LTE cellular modem with European bands |
| POE/4RSM/LTEEU | PoE on 8 x 10/100BASE-T ports up to 120W, 2 x RS-232 and 2 x RS-485 ports, LTE cellular modem with European bands |
| LTEEU | LTE cellular modem with European bands |

| SUFFIX | Optional Power over Ethernet (PoE) + Interface |
|---|--|
| SF2/S/24VDC/2GE8UTP/& | |
| Routing with secured VPN and serial gateway, 24 VDC (20–32 VDC) power supply, 2×GbE SFP and 8x10/100BASE-T Ethernet ports | |
| & RS232 | 4 x RS-232 ports |
| RS232/CEL | 4 x RS-232 ports, GPRS/UMTS cellular modem |
| LTEEU | LTE cellular modem with European bands |
| RS232/HSPAP | 4 x RS-232 ports, high-speed packet access modem, 3.5G |
| RS232/LTEEU | 4 x RS-232 ports, LTE cellular modem with European bands |
| RS232/LTENA | 4 x RS-232 ports, LTE cellular modem with North American bands |
| SF2/B/AC/2GE8UTP/\$ | |
| Basic option with Ethernet features, 90–240 VAC power supply, 2×GbE SFP and 8x10/100BASE-T Ethernet ports | |
| \$ CEL | GPRS/UMTS cellular modem |
| POE/RS232 | PoE on 8 x 10/100BASE-T ports up to 120W, 4 x RS-232 ports |
| POE/RS232/CEL | PoE on 8 x 10/100BASE-T ports up to 120W, 4 x RS-232 ports, GPRS/UMTS cellular modem |
| RS232 | 4 x RS-232 ports |
| RS232/CEL | GPRS/UMTS cellular modem |
| POE | PoE on 8 x 10/100BASE-T ports up to 120W |
| POE240W | PoE on 8 x 10/100BASE-T ports up to 240W |

OPTIONAL ACCESSORIES

SF-AC-48VDC-120W

External DIN rail AC to 48 VDC power supply, 120W, -20 to 60°C (-4 to 140°F); 60W at 65°C (149°F) and above

CBL-SF-RJ45-CONSOLE

Console port cable

CBL-RJ45/DB9/NULL

Serial port cable

CBL-SF-ALARM

SecFlow alarm port cable

SF-ANT3G-2M

Outdoor antenna for 3G cellular modem, 2m connecting cable

SF-ANT3G-5M

Outdoor antenna for 3G cellular modem, 5m connecting cable

SF-ANT4G-2M

Outdoor antenna for SecFlow 4G cellular modem, 2m connecting cable, 3dBi, 699-960 MHz/1710-2170 MHz/2500-2690 MHz

SF-ANT4G-5M

Outdoor antenna for SecFlow 4G cellular modem, 5m connecting cable, 3 dBi, 699-960 MHz/1710-2170 MHz/2500-2690 MHz

International Headquarters

24 Raoul Wallenberg St., Tel Aviv 6971923, Israel
Tel 972-3-6458181 | Fax 972-3-7604732
Email market@rad.com

North American Headquarters

900 Corporate Drive, Mahwah, NJ 07430, USA
Tel 201-529-1100 | Toll Free: 800-444-7234 | Fax: 201-529-5777
Email market@radusa.com



Your Network's Edge®

www.rad.com

622-100-07/20 (4.3) Specifications are subject to change without prior notice. © 2013–2020 RAD Data Communications Ltd. The RAD name, logo, logotype, and the product names Airmux, IPmux, MiNID, MiCLK, Optimux, and SecFlow are registered trademarks of RAD Data Communications Ltd. All other trademarks are the property of their respective holders.