

# Megaplex-1

## Multiservice Pseudowire Access Gateway



- Grooming, consolidating and transmitting analog voice and TDM-based services over Ethernet, IP or MPLS networks using standard-compliant pseudowire technology
- Bridge functionality for packet switched networks with 2 optical/copper GbE uplinks and up to 4 FE user interfaces
- Hitless PW redundancy
- Wide range of services including: E1/T1, FXS or E&M toll-quality analog voice channels, IEEE C37.94-compliant optical tele-protection, programmable serial ports
- 1U, 19" fanless enclosure with redundant wide-range power supply (AC and DC)

Megaplex-1 is a multiservice pseudowire gateway that transports analog and TDM traffic (originating from legacy circuit-switched networks) over packet-switched networks (PSNs).

### MARKET SEGMENTS AND APPLICATIONS

Various users can benefit from the Megaplex-1 solution:

- Users with mixed Ethernet and TDM services
- Users looking for a future-proof migration path to IP connectivity
- Owners of facilities sensitive to space or climate constraints

Its ability to handle a broad range of Ethernet, data and voice services in a single compact managed node, makes Megaplex-1 an ideal access solution for diverse network operators and service providers. It also provides a perfect fit for utilities and transportation companies that require an efficient way to transport and provision multiple legacy and next-generation services over their high capacity pipes.

Megaplex-1 (specific ordering options) is certified for Railway applications with EN50121-4.

### SERVICES

Megaplex-1 provides a variety of services, via its many user interfaces, such as:

- E1/T1 ports
- IEEE C37.94 fiber optic teleprotection ports
- Serial synchronous/asynchronous data ports
- Voice ports (FXS, E&M)
- Fast Ethernet (10/100BASE-T)

### ETHERNET SWITCH

Megaplex-1 features a powerful internal Layer-2 Ethernet switch that provides Ethernet user ports with rate limiting and VLAN-based/port-based classification capabilities.

Megaplex-1 includes the following Ethernet ports:

- Two fiber optic or copper Gigabit Ethernet network (NNI) ports
- Four or two copper Fast Ethernet user (UNI) ports (available on some ordering options)
- One copper FE port for out-of-band management.

# Megaplex-1

## Multiservice Pseudowire Access Gateway

The GbE Network (NNI) ports provide the physical connection to the packet switched network. These ports provide Megaplex-1 with a multirate FE/GE interface, for optical or electrical media, and can be ordered with one of the following interfaces:

- 10/100/1000BASE-T copper ports. This type of ports support autonegotiation, with user-specified advertised data rate (10, 100 or 1000 Mbps) and operating mode (half- or full-duplex).

The ports also support automatic polarity and crossover detection, and polarity correction, for connection through any type of cable to any type of Ethernet port (hub or station).

Alternatively, autonegotiation can be disabled and the rate and operating mode be directly specified.

- SFP sockets, for installing 100/1000BASE-FX SFP plug-in modules. Support for standard SFP optical transceivers for the GbE link interfaces enables selecting the optimal interface for each application. This type of ports does not support autonegotiation. RAD offers a wide variety of SFPs, for meeting a wide range of operational requirements.

The UNI Ethernet interface has two or four 10/100BASE-T interface terminated in RJ-45 connectors capable of autonegotiation. The user can configure the advertised data rate (10 or 100 Mbps) and operating mode (half-duplex or full-duplex). Alternatively, autonegotiation can be disabled, and the rate and operating mode be directly specified. In addition to autonegotiation, MDI/MDIX polarity and cross-over detection and automatic cross-over correction are also supported.

### PSEUDOWIRE

The device uses its embedded pseudowire engine to encapsulate the user services for low-latency transmission over packet-switched networks.

The powerful pseudowire engine provides up to 6 protected (or up to 12 unprotected) PWs with up to 31 timeslots per each PW port.

A remote pseudowire device converts the packets back to the original user traffic format.

### E1/T1

Megaplex-1 has 8 independently configurable E1/T1 ports.

The E1 interface is compatible with all carrier-provided E1 services, meeting the requirements of ITU-T Rec. G.703, G.704 and G.732.

It operates in framed mode as per G.732, as well as in unframed mode. CRC-4 is also supported, complying with G.704 recommendations. Zero suppression over the line is HDB3.

The T1 interface is compatible with ANSI requirements. Both D4 and ESF framing formats are supported. Line code is selectable for AMI or B8ZS.

### SERIAL DATA TRAFFIC

The serial data rates are independently selectable for each channel and depend on the selected encapsulation mode:

- **None:** each channel operates at high speed rates of  $n \times 56$  or  $n \times 64$  kbps, where  $n = 1$  to 31 (that is, maximum 1984 kbps).
- **V110:** each channel operates at low speed sync rates of 2.4, 4.8, 9.6, 19.2 or 38.4 kbps, performing rate adaptation in accordance with ITU-T Rec. V.110.
- **3-bit transitional:** the interface provides transitional encoding to transmit asynchronous data at rates up to 19.2/38.4 kbps. It operates by encoding asynchronous data in a 3-bit transitional code, which is then transmitted over the Megaplex uplink at a rate of 64/128 kbps. This mode covers all asynchronous character formats.

The interface terminates in one or two 68-pin SCSI-4 female connectors (according to the ordering option). Each connector includes 3 channels. This provides a simple and easy SW-configurable selection of serial interface (V.35, RS-422 or RS-232) according to the deployment needs.

Adapter cables, available upon order, are offered by RAD to split each connector into three separate channel interfaces with standard connectors: V.35, RS-530, RS-232, X.21 or V.36/RS-449.

Each channel has local support of interface control signals (CTS, RTS, DCD, DSR and DTR). In addition, each channel can be configured to transmit control signals end-to-end.

Table 1. Transmit and Receive Levels for Voice Interfaces

Interface	Transmit [dbm]		Receive [dbm]	
	min	max	min	max
E&M 2W	-8	+5	-17	+2
E&M 4W (when there is a mix of 2W/4W ports)	-8	+5	-17	+3.5
E&M 4W (all ports)	-17	+5	-17	+9
FXS	-5	+5	-17	+1

# Megaplex-1

## Multiservice Pseudowire Access Gateway

### OPTICAL TELE-PROTECTION

The interface can be used for both user and network ports – either for inter-substation communication or for transmitting distance teleprotection information.

The dual-port fiber optic interface operates at a nominal wavelength of 850 nm and nominal line rate of 2.048 Mbps. Each port is terminated in a pair of ST connectors for connection to standard multimode fiber.

The interface complies with IEEE C37.94 standard for distances of up to 2 km.

### VOICE TRAFFIC

The voice interface provides 8 FXS or 4 E&M toll-quality analog voice channels. Voice signals are digitized using PCM, in compliance with ITU-T G.711 and AT&T Pub. 43801 standards.

Encoding and decoding are in full compliance with ITU-T requirements G.711. Voice channel companding is selectable for A-law or  $\mu$ -law.

The E&M interface operates with different types of E&M signaling: EIA RS-464 Types I, II, III and V (British Telecom SSDC5). Both 2-wire and 4-wire lines are supported (user-selectable).

The E&M interface provides EIA RS-464 Type I signaling without the need for an external DC power supply. For other signaling types, the internal -12 VDC provided by the chassis is sufficient for connection to most PBX systems.

However, for *full* support of EIA RS-464 Types II, III and V (BT SSDC5) standards, a -48 VDC power source is required.

The E&M interface provides signaling at +12V for applications that require positive signaling voltage (for example, radio transmitters) and perform fault propagation.

The FXS interface employs both loop-start and wink-start signaling methods. FXS interfaces are typically used for direct connection to 2-wire telephones in the following loop-start applications:

- Off-Premises Extension (OPX), where a local telephone on the PBX can be connected to an off-premises telephone, by dialing only the extension number;
- Private Line, Automatic Ringdown application (PLAR) (also referred to as Hot Line), where two telephones are connected directly via the E1/T1 link. When the telephone on one side goes off-hook, the other telephone rings;
- Direct connection to 2-wire telephones in PSTN applications.

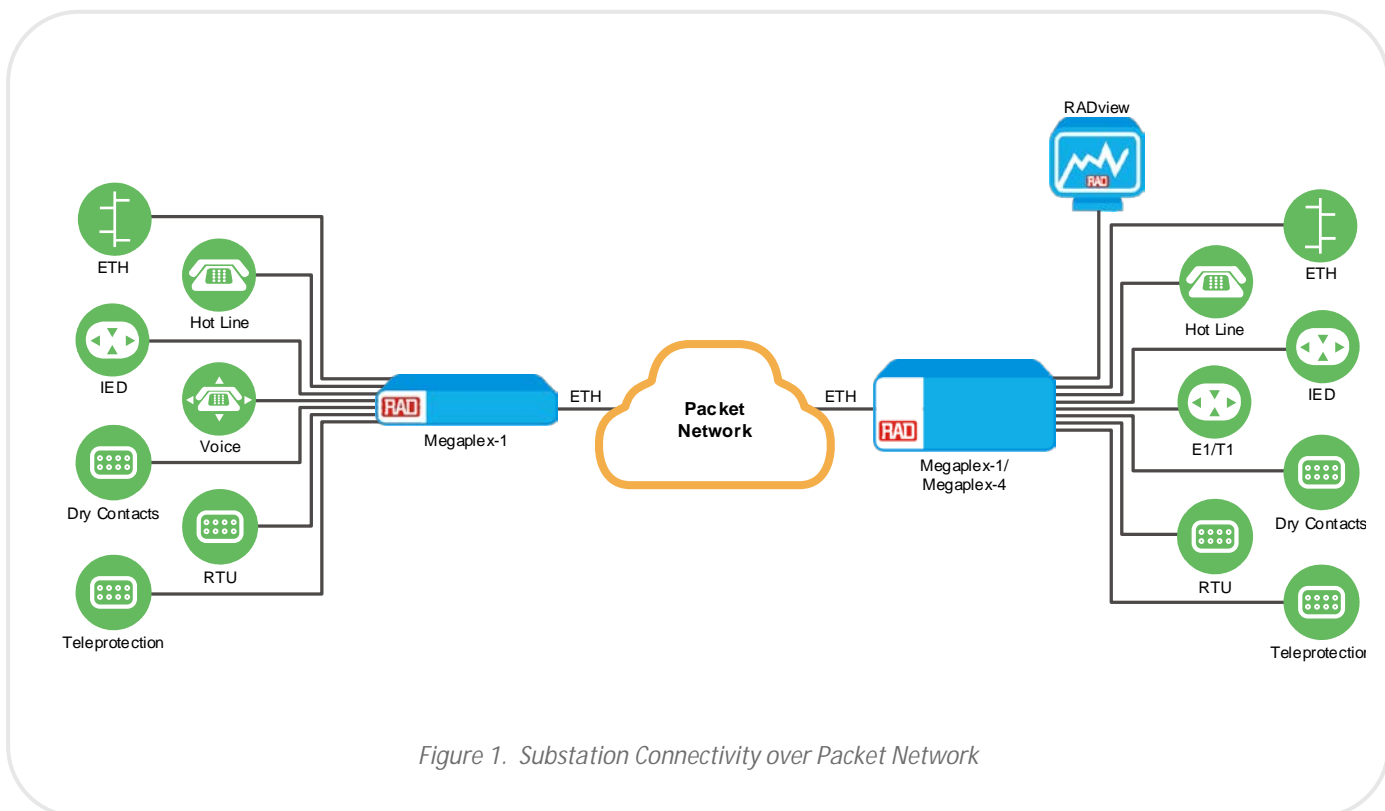

Figure 1. Substation Connectivity over Packet Network

# Megaplex-1

## Multiservice Pseudowire Access Gateway

When operating in PCM mode, battery polarity is reversed for wink-start signaling, used in direct inward dialing (DID) applications.

Both E&M and FXS interfaces require a nominal -48 VDC (-37 to -75 VDC) source. This power can be provided either by an appropriate DC-powered chassis, or by an external standalone Ringer power supply unit in accordance with the number of ports.

Gain control is user-selectable for both receive and transmit directions, enabling easy installation in all environments.

### RESILIENCY

Service reliability in Megaplex-1 is based on the following resiliency features:

- Fanless operation
- Redundant wide range power supply
- Dual NNI ports
- Hitless PW protection

### MANAGEMENT AND SECURITY

The device can be managed via RADview, RAD's carrier-class NMS, or any SNMP-based management system. Megaplex-1 supports a variety of access protocols, including CLI over Telnet, SNMPv3, and TFTP. Security features include SNMPv3, RADIUS (client authentication), TACACS+ (client authentication, authorization, and accounting), SSH, and SFTP. Access Control Lists (ACL) can also be used to flexibly filter and mark management traffic, enabling service providers to maintain network security by dropping unwanted packets.

### MONITORING AND DIAGNOSTICS

Comprehensive diagnostic capabilities include:

- Local and remote loopbacks
- Real-time alarms to alert the user on fault conditions

Megaplex-1 collects statistics per physical port and per connection for 15-minute intervals, which enables the network operator to monitor the transmission performance and thus the quality of service provided to users, as well as identify transmission problems. Statistics for the last 24 hours are stored in the device and can be retrieved by the network management station.

The Performance Management Portal is an SLA assurance system that is part of the RADview management system, enabling real-time monitoring of Ethernet service performance by collecting KPI data from RAD devices.

### Specifications

#### E1 INTERFACE

Compliance	ITU-T G.703, G.704, G.732
Framing	Framed per G.732: <ul style="list-style-type: none"> <li>· with or without CAS</li> <li>· with or without CRC-4</li> </ul> Unframed
Data Rate (per port)	2.048 Mbps
Line Code	HDB3
Signal Level	Receive: 0 to -12 dBm Transmit: Balanced: $\pm 3V$ ( $\pm 10\%$ ) Unbalanced: $\pm 2.37V$ ( $\pm 10\%$ )
Jitter Performance	As per ITU-T G.823
Impedance	Balanced 4-wire: 120W Unbalanced coax: 75W

#### T1 INTERFACE

Compliance	ANSI T1.107 and T1.403
Framing	ESF, D4
Data Rate (per port)	1.544 Mbps
Line Code	AMI, B8ZS
Signal Level	Receive: 0 to -12 dBm Transmit: 0.6, 1.2, 1.8, 2.4, 3.0 dBm user-adjustable, measured at 0 to 655 ft
Jitter Performance	As per AT&T TR-62411
Impedance	Balanced 4-wire: 100W
Connectors	DB-44, female (see <i>Ordering</i> for cables available from RAD)

#### SERIAL INTERFACE

Encapsulation Modes and Data Rates	None: n' 56 or n' 64 kbps (n = 1 to 31) V110: 2.4, 4.8, 9.6, 19.2, 38.4 kbps 3-bit-transitional: 64 kbps, 128 kbps
Interface (Electrical)	V.24/RS-232, V.35 or V.11/RS-422 RS-485 (4-wire master only)
Interface (Physical)	V.24/RS-232, V.35, V.36/RS-449, RS-530, X.21 (via adaptor cables)
Connectors	One/two 68-pin SCSI, female (one per 3 data channels)
Interface Control Signals	Local support for all types of control signals End-to-end transfer of local RTS and DTR lines
Signal Format	Asynchronous or synchronous, full duplex
Clock Mode	DCE (channel provides both RX and TX clocks to the user DTE)
Diagnostics (per port)	Local digital loopback Remote digital loopback

#### C37.94 INTERFACE

Compliance	IEEE C37.94, optical part
Number of Ports	2
Connectors	Pair of ST connectors, female
Nominal Data Rate	2.048 Mbps
Wavelength	850nm $\pm$ 40nm
Fiber Type	62.5/125 mm multimode 50/125 mm multimode
Transmitter Type	LED
Power Coupled into Fiber	62.5/125 mm: -11 to -19 dBm 50/125 mm: -11 to -23 dBm
Minimum Receiver Sensitivity	-32 dBm
Maximum Receiver Input Power	-11 dBm
Receiver Dynamic Range	21 dB
Range (Typical)	2 km/1.25 miles

# Megaplex-1

## Multiservice Pseudowire Access Gateway

LED Indicators	SYNC (green/red):
	<ul style="list-style-type: none"> <li>Lights steadily in green – the corresponding port is operating properly</li> <li>Flashes in green – the corresponding port is operating properly, but serves as the standby port when link protection is enabled</li> <li>Lights in red – the corresponding port detects loss of synchronization or loss of signal</li> <li>Flashes in red – the corresponding port serves as the standby port, and detects loss of synchronization</li> </ul>
	REM SYNC (yellow):
	<ul style="list-style-type: none"> <li>On – the corresponding port detects loss of remote synchronization</li> <li>Off – the corresponding port is not connected.</li> </ul>
Diagnostics (per port)	Local digital loopback
	Remote digital loopback

### VOICE INTERFACE – GENERAL

Voice Encoding Technique	Per ITU-T G.711 and AT&T Pub. 43801, $\mu$ -law or A-law
Diagnostics	Local digital loopback for each channel, towards the local user equipment
	Remote digital loopback for each channel, towards the remote user equipment
	1 kHz, 0 dBm0 test tone injection for each channel, towards the remote user equipment
	1 kHz, 0 dBm0 backward test tone injection for each channel, towards the local user equipment
Nominal level	0 dBm
Nominal Impedance	600W
Return loss (ERL)	at 300 to 3400 Hz: better than 20 dB
Frequency response (Ref:1020 Hz)	$\pm 0.5$ dB at 300 to 3000 Hz
	$\pm 1.1$ dB at 250 to 3400 Hz
Level adjustment	Soft-selectable, see Table 1
Steps	0.5 dB ( $\pm 0.5$ dB), nominal
Signal to total distortion (G.712)	-30 to 0 dBm0: better than 33 dB
	-45 to +3 dBm0: better than 22 dB
Idle channel noise	better than -65 dBm0 (+25 dBnc)
Far-end cross-talk (2W&4W)	-65dBm0 max
Go-to-return cross-talk (4W)	-60dBm0 max

### E&M INTERFACE

Number of Ports	4
Line Type	4-wire or 2-wire (soft-selectable)
Connectors	4 x RJ-45
Signaling Method (selectable)	EIA RS-464 Type I
	EIA RS-464 Types II, III, and V (British Telecom SSDC5) using -12 VDC in place of -48 VDC
	<i>Note: For full support of Types II, III, and V (SSDC5) signaling standards, -48 VDC power supply is required.</i>
Pulse Dial Distortion	$\pm 2$ ms max
Transformer Isolation	1500 VRMS
Indicators	M – On when the M line of the corresponding channel is off-hook (channel in use)
	E – On when the E line of the corresponding channel is off-hook (channel in use)

### FXS INTERFACE

Number of Ports	8
Line Type	2-wire (ITU-T standard: G.712)
Connectors	4 x RJ-12 (one per two channels)
Signaling Methods	EIA RS-464 loop-start or wink-start
On-Hook/Off-Hook Threshold	Off-Hook: Loop current >11 mA
	On-Hook: Loop current <8 mA
Indicators	Number: 8
	Color: green/yellow
	Name: LOC/REM
	Lights steadily in green – Local "OFF-HOOK"
	Lights steadily in yellow – Remote "OFF-HOOK"
	Flashes in green/yellow – Local and Remote "OFF-HOOK"/conversation state
	Off: port is not connected or both directions of signaling are "ON-HOOK"
Loop Resistance	Min: 300 $\Omega$
	Max: 1600 $\Omega$
Feed Current	20 mA ( $\pm 10\%$ ) per active channel
Ringer	Overload protected, 1 sec ON, 3 sec OFF
	54 VRMS with up to 1 REN load
	45 VRMS with up to 5 REN load
Reverse Polarity Pulse Distortion	6 ms max

# Megaplex-1

## Multiservice Pseudowire Access Gateway

-48 VDC (nominal) Current Consumption	30 mA ( $\pm 10\%$ ) per active channel
Number of Channels	Ringer-2100R: up to 40 Ringer-2000: up to 100 Ringer-2200N: up to 200

### GBE INTERFACE

Number of Ports	2 UTP copper (RJ-45 shielded) or 2 SFP sockets
Data Rate	UTP: 10/100/1000 Mbps SFP: 100/1000 Mbps
Autonegotiation	copper only
Frame Size	9140 bytes
LED Indicators	LINK On (green): Link is up LINK Off: Link is down ACT Flashes (yellow): Data is being transferred ACT Off: No data transfer
SFP Transceivers	For full details, see the <a href="#">SFP/XFP Transceivers data sheet</a> on <a href="http://www.rad.com">www.rad.com</a>  <i>Note. It is strongly recommended to order this device with original RAD SFPs. RAD cannot guarantee full compliance to product specifications for units using non-RAD SFPs.</i>

### FAST ETHERNET INTERFACE

Number of Ports	4 x 10/100BaseT
Data Rate	10/100 Mbps (Fast Ethernet) Autonegotiation
Connectors	RJ-45, shielded
Frame Size	9140 bytes
LED Indicators	LINK On (green): Link is up LINK Off: Link is down ACT Flashes (yellow): Data is being transferred ACT Off: No data transfer

### PSEUDOWIRE

Standard Compliance	IETF RFC 5086 (CESoPSN) MEF 8
Number of PW Connections	Up to 12 (unprotected) Up to 6 (fully protected)
Jitter Buffer Size	0.25 –256 ms, in 1 $\mu$ s steps with 125 $\mu$ s granularity (the value entered by the user is rounded upward to the closest $n \times 125 \mu$ s value)
Diagnostics (per DS1 port or timeslot)	Local digital loopback Remote digital loopback

### MANAGEMENT

Connectivity	Out-of-band, via serial control or Ethernet management port Inband, via NNI Ethernet ports
Control Port	RS-232 interface, RJ-45 connector
Ethernet Management Port	Interface: 10/100/1000BASE-T Autonegotiation Connector: RJ-45
Tools	Telnet/SSHv2, SNMPv3, SFTP RADIUS, TACACS+
Options	CLI RADview management and VF orchestration suite Standalone Shelf View application

# Megaplex-1

## Multiservice Pseudowire Access Gateway

### TIMING

<b>Clock Sources</b>	Users can define the following clock sources: Internal crystal free-running oscillator-based clock Derived from the receive clock of a specified user port Adaptive clock recovered (ACR) from a pseudowire circuit External station clock
<b>Internal Clock Quality</b>	ST-4
<b>ACR (Adaptive Clock Recovery)</b>	Supports jitter and wander requirements according to G.8261, G.823 and G.824 traffic interface recommendations with quality precision of $\pm 16$ ppb
<b>Station Clock</b>	Line code: AMI/HDB3/B8ZS Mode: Input and output Impedance: 120W, balanced 75W, unbalanced (via adapter cable) Bit rate: 2.048 MHz/2.048 Mbps (E1) 1.544 Mbps (T1) Connector: RJ-45

### DIAGNOSTICS

<b>Alarm Relay</b>	1 inbound relay – RS-232 levels (dry contact) 2 outbound relays triggered by major/minor alarms Operation: normally open, normally closed, using different pins
<b>Loopbacks</b>	Local and remote loopbacks (see under various interfaces) BERT per timeslot of internal DS1 port

### GENERAL

#### Power

<b>Power Supply</b>	AC: 100-240 VAC ( $\pm 10\%$ ), 50/60 Hz DC: 48 VDC (40-60 VDC) Autodetection
<b>Power Consumption</b>	30W (max.)

#### Physical

<b>Height</b>	44 mm (1.73 in)
<b>Width</b>	440 mm (17 in)
<b>Depth</b>	325 mm (12.8 in)
<b>Weight</b>	4.1 kg (9 lb) max.

#### Environment

Designed for future IEEE-1613 compliance

<b>Storage</b>	-20°C to +70°C (-4°F to +160°F)
<b>Operating Temperature</b>	-20°C to 65°C (-4°F to 149°F) <i>Note: When working with other devices, operating temperature depends on their temperature limits: for example, with MiTOP-E3T3-GbE it is up to 55°C (131°F).</i>
<b>Humidity</b>	up to 95%, non-condensing



# Megaplex-1

## Multiservice Pseudowire Access Gateway

### Ordering

#### RECOMMENDED CONFIGURATIONS

**MP-1/PSR/2GEU/4FEU/6S/8E1T1**

**MP-1/PSR/2GES/4FEU/6S/8E1T1**

Uplink ports: 2 GbE ports with 10/100/1000BASE-T copper or empty SFP receptacles

User ports: 6 serial ports, 8 E1/T1 ports, 4 Fast Ethernet copper ports

Redundant power supplies

**MP-1/PSR/2GEU/4FEU/6S/C37**

**MP-1/PSR/2GES/4FEU/6S/C37**

Uplink ports: 2 GbE ports with 10/100/1000BASE-T copper or empty SFP receptacles

User ports: 6 serial ports, 2 C37.94 ports, 4 Fast Ethernet copper ports

Redundant power supplies

**MP-1/PSR/2GEU/4FEU/6S/4E&M**

**MP-1/PSR/2GES/4FEU/6S/4E&M\***

Uplink ports: 2 GbE ports with 10/100/1000BASE-T copper or empty SFP receptacles

User ports: 6 serial ports, 4 E&M voice ports, 4 Fast Ethernet copper ports

Redundant power supplies

\*certified for Railway applications with EN50121-4

**MP-1/PSR/2GEU/4FEU/8FXS/4E&M**

**MP-1/PSR/2GES/4FEU/8FXS/4E&M**

Uplink ports: 2 GbE ports with 10/100/1000BASE-T copper or empty SFP receptacles

User ports: 4 E&M voice ports, 8 FXS voice ports

Redundant power supplies

**MP-1/PS/2GEU/2FEU/3S**

**MP-1/PS/2GES/2FEU/3S\***

Uplink ports: 2 GbE ports with 10/100/1000BASE-T copper or empty SFP receptacles

User ports: 3 serial ports, 2 Fast Ethernet copper ports

Single power supply

\*certified for Railway applications with EN50121-4

**MP-1/PS/2GEU/2FEU/4E&M**

**MP-1/PS/2GES/2FEU/4E&M**

Uplink ports: 2 GbE ports with 10/100/1000BASE-T copper or empty SFP receptacles

User ports: 4 E&M voice ports, 2 Fast Ethernet copper ports

Single power supply

# Megaplex-1

## Multiservice Pseudowire Access Gateway

### SPECIAL CONFIGURATIONS

Please contact your local RAD partner for additional configuration options.

### SUPPLIED ACCESSORIES

Alarm connector  
2 DC power inlet adapters  
2 AC power cables  
TB plug for Ringer connection (E&M or FXS options only)  
**CBL-RJ45/D9/F/6FT**  
Control cable  
**RM-50**  
Hardware kit for mounting one Megaplex-1 unit in a 19-inch rack

### OPTIONAL ACCESSORIES

**CBL-SCS68/3/\*/#/¶/¶**  
Cable for converting each of the VS 68-pin SCSI connectors into 3 separate channel connectors with the physical interface specified.  
*Note: A separate cable is required for each of the 2 channel connectors.*

#### Legend

\* Interface:  
232 V.24/RS-232, 25-pin  
V35 V.35 interface, 34-pin  
V36 V.36/RS-449, 37-pin  
530 RS-530, 25-pin  
X21 X.21, 15-pin  
# Length (Default=2m / 6.5 ft):  
3M for 3m (9.8 ft)  
5M for 5m (16.4 ft)  
& Connector:  
F female  
M male

### CBL-G703-8/RJ45

Splitter cable for splitting 44-pin E1/T1 connector to 8 E1 or 8 T1 balanced RJ-45 connectors

### CBL-G703-8/RJ45/X

Splitter cross-cable for splitting 44-pin E1/T1 connector to 8 E1 or 8 T1 balanced RJ-45 connectors

### CBL-G703-8/COAX

Splitter cable for splitting 44-pin connector to 8 pairs of unbalanced connectors for E1 applications

### CBL-G703-8/OPEN

Open-ended cable with DB-44 connector on the Megaplex side for balanced E1 or T1 applications

All the cables listed in this section are 2m (6.6 ft) long. For additional cable lengths available, contact your local sales representative.

### CBL-VS-VOICE

Cable for splitting each of the four RJ-12 connectors of FXS interface into two RJ-12 connectors intended for end-user equipment

The default cable length is 1m/3.3 ft. For additional cable lengths available, contact your local sales representative

#### International Headquarters

24 Raoul Wallenberg St., Tel Aviv 6971923, Israel  
Tel 972-3-6458181 | Fax 972-3-7604732  
Email [market@rad.com](mailto:market@rad.com)

#### North American Headquarters

900 Corporate Drive, Mahwah, NJ 07430, USA  
Tel 201-529-1100 | Toll Free: 800-444-7234 | Fax: 201-529-5777  
Email [market@radusa.com](mailto:market@radusa.com)



Your Network's Edge®

[www.rad.com](http://www.rad.com)

694-100-11/20 (2.2) Specifications are subject to change without prior notice. © 2016–2020 RAD Data Communications Ltd. RAD products/technologies are protected by registered patents. To review specifically which product is covered by which patent, please see [ipr.rad.com](http://ipr.rad.com). The RAD name, logo, logotype, and the product names MINID, Optimux, Airmux, IPmux, and MICKL are registered trademarks of RAD Data Communications Ltd. All other trademarks are the property of their respective holders.